



PRODUCT CATALOG

Manufacturers of Engineered Joining
Solutions for the Clamping Industry



Table of Contents

Clampco Products, Inc. is the leading USA manufacturer of engineered joining solutions for the clamping industry.

ABOUT US

About Clampco	2
The Clampco Approach.....	3
Quality Certifications	3

T-BOLT CLAMPS

Standard/Stock Items.....	4
Made-to-Order.....	6
Spring-Loaded Clamps.....	10
Marine Grade Clamps.....	12
Military MS21920 Clamps	13

BARREL HARDWARE CLAMPS

Zinc Plated & Stainless Steel Barrels	14
---	----

WORM GEAR CLAMPS

Zinc Plated & Stainless Steel Worm.....	16
---	----

V-BAND CLAMPS/COUPLINGS

Standard/Stock Items.....	17
Made-to-Order.....	18

FLANGES

Machined Flanges (No Gasket).....	24
Formed Sheet Metal Flanges.....	25

STRAPS & STRAP ASSEMBLIES

Made-to-Order.....	26
--------------------	----

CLAMPKO CUSTOM DESIGN PRODUCTS

Clampco Custom Design Products.....	28
-------------------------------------	----

LATCHES, FASTENERS & HANDLES

Custom Options	30
----------------------	----

CUSTOM AEROSPACE & DEFENSE

Custom Aerospace & Defense Clamps	32
---	----

TESTING CAPABILITIES

Testing Capabilities	33
----------------------------	----

HOW TO DETERMINE SIZE

Nominal Size for your Hose Clamp Application.....	34
Proper Dimensions for your V-Band Coupling Application.....	35

ENGINEERING DATA & SPECIFICATIONS

Engineering Data & Specifications.....	36
--	----





Clampco Products

Wadsworth, Ohio • Founded 1971

Clampco Products, Inc. is the leading USA manufacturer of engineered joining solutions. Our stainless steel T-Bolt Band Clamps, V-Band Clamps/Couplings, Spring-Loaded Clamps, Worm Gear Hose Clamps and Strap Assemblies can be found wherever rubber hoses, plastic tubing, solid objects or other parts must be fastened, joined or securely connected.

Clampco Products is proud to remain a family-owned business producing Made in the USA products in Wadsworth, Ohio. Clampco Products currently serves commercial and industrial companies in a wide variety of markets including the aerospace, construction, filtration, irrigation, marine, material handling, medical, on/off-road vehicles, rail and water treatment industries. Clampco also supplies many well-known international customers and is certified to AS9100/ISO 9001 and ISO 14001.



James Venner, Linda Venner and Jason Venner

THE CLAMPKO APPROACH

Clampco differentiates ourselves by offering a Solution Based Sales Approach that focuses on customer needs. Our proven 6-Step Approach provides a disciplined process that helps our customers:

- Develop new products quickly, while reducing cost
- Quickly solve customer problems by leveraging our decades of clamp manufacturing experience



QUALITY CERTIFICATIONS

Clampco is proud to be registered and operate our Quality Management System under AS9100/ISO 9001 and ISO 14001 Certifications. Certification to these globally recognized standards provides our customers the confidence that Clampco maintains a culture of quality and continuous improvement, while operating in an environmentally responsible manner.

***Note that all current Quality Certifications can be found on our website, www.clampco.com**



AS9100 is the International Quality Management System standard for the Aviation, Space and Defense industries. The AS9100 aerospace standard is based on the ISO 9001 quality system with additional requirements to meet the critical needs of FAA, NASA and DOD. Less than 10 clamp manufacturers globally share this esteemed quality certification. Clampco is honored to serve as a trusted supplier to our Aerospace and Defense customers.

ISO 9001 is defined as the international standard that specifies requirements for a quality management system (QMS). Organizations use the standard to demonstrate the ability to consistently provide products and services that meet customer and regulatory requirements. Maintaining the ISO 9001 standard assures our Commercial and Industrial customers that Clampco meets their specific requirements and expectations.

ISO 14001 is the international standard that specifies requirements for an effective environmental management system (EMS). ISO14001 helps Clampco improve our environmental performance through more efficient use of resources and reduction of waste, looking closely at all environmental issues relevant to its operations. Certification to this important international standard shows proof of Clampco's commitment to a cleaner environment and reduced carbon footprint to our customers.

T-BOLT BAND CLAMPS

Standard/Stock Items



Ready to Deliver!

Our Most Popular 300 Series Stainless Steel T-Bolt Band Clamps in Standard T-Bolt, Channel Tongue and Floating Bridge styles.

Clampco T-Bolt Band Clamps provide leak-proof connections in a wide variety of industrial, commercial and military applications. We manufacture our clamps from 300 series stainless steel with rounded band edges to protect soft hose materials. Our T-Bolt Band Clamps provide high tensile strength, durability and corrosion resistance. They are the perfect choice for medium and heavy-duty applications.

Clampco T-Bolt Band Clamps are frequently installed on coolant and air-intake systems for construction vehicle, truck and bus engines. They are also widely used on duct systems, baghouse filters, irrigation systems, medical equipment, precleaners and more.



SPECIFICATIONS



94100, 941RC, and 94170 Series
Band 0.025 in. Thick x 0.75 in. Wide

ZINC PLATED T-BOLT AND LOCKNUT

Maximum Torque 90 in.-lbs. (dry)

ENGLISH (inches)					
STANDARD T-BOLT NO.	CHANNEL TONGUE NO.	FLOATING BRIDGE NO.	NOMINAL DIAMETER	MINIMUM DIAMETER	MAXIMUM DIAMETER
94100-0125	941RC-0125	94170-0125	1.25	1.11	1.25
94100-0150	941RC-0150	94170-0150	1.50	1.36	1.50
94100-0162	941RC-0162	94170-0162	1.62	1.48	1.62
94100-0175	941RC-0175	94170-0175	1.75	1.62	1.87
94100-0188	941RC-0188	94170-0188	1.88	1.75	2.00
94100-0200	941RC-0200	94170-0200	2.00	1.87	2.12
94100-0212	941RC-0212	94170-0212	2.12	1.93	2.24
94100-0225	941RC-0225	94170-0225	2.25	2.06	2.37
94100-0238	941RC-0238	94170-0238	2.38	2.19	2.50
94100-0250	941RC-0250	94170-0250	2.50	2.31	2.62
94100-0256	941RC-0256	94170-0256	2.56	2.37	2.68
94100-0262	941RC-0262	94170-0262	2.62	2.43	2.74
94100-0275	941RC-0275	94170-0275	2.75	2.56	2.87
94100-0288	941RC-0288	94170-0288	2.88	2.66	2.97
94100-0300	941RC-0300	94170-0300	3.00	2.78	3.09
94100-0312	941RC-0312	94170-0312	3.12	2.90	3.21
94100-0325	941RC-0325	94170-0325	3.25	3.03	3.34
94100-0350	941RC-0350	94170-0350	3.50	3.28	3.59
94100-0362	941RC-0362	94170-0362	3.62	3.40	3.71
94100-0375	941RC-0375	94170-0375	3.75	3.53	3.84
94100-0388	941RC-0388	94170-0388	3.88	3.66	3.97
94100-0400	941RC-0400	94170-0400	4.00	3.78	4.09
94100-0425	941RC-0425	94170-0425	4.25	4.03	4.34
94100-0438	941RC-0438	94170-0438	4.38	4.16	4.47
94100-0450	941RC-0450	94170-0450	4.50	4.28	4.59
94100-0475	941RC-0475	94170-0475	4.75	4.53	4.84
94100-0500	941RC-0500	94170-0500	5.00	4.78	5.09
94100-0550	941RC-0550	94170-0550	5.50	5.28	5.59
94100-0600	941RC-0600	94170-0600	6.00	5.78	6.09
94100-0625	941RC-0625	94170-0625	6.25	6.03	6.34
94100-0650	941RC-0650	94170-0650	6.50	6.28	6.59
94100-0700	941RC-0700	94170-0700	7.00	6.78	7.09
94100-0750	941RC-0750	94170-0750	7.50	7.28	7.59
94100-0766	941RC-0766	94170-0766	7.66	7.44	7.75

S = Stock Items

94106, 94166, and 941QA Series
Band 0.025 in. Thick x 0.75 in. Wide

STAINLESS STEEL T-BOLT AND LOCKNUT

Maximum Torque 75 in.-lbs. (dry)

ENGLISH (inches)					
STANDARD T-BOLT NO.	CHANNEL TONGUE NO.	FLOATING BRIDGE NO.	NOMINAL DIAMETER	MINIMUM DIAMETER	MAXIMUM DIAMETER
94106-0125	94166-0125	941QA-0125	1.25	1.11	1.25
94106-0138	94166-0138	941QA-0138	1.38	1.24	1.38
94106-0150	94166-0150	941QA-0150	1.50	1.36	1.50
94106-0162	94166-0162	941QA-0162	1.62	1.48	1.62
94106-0175	94166-0175	941QA-0175	1.75	1.62	1.87
94106-0188	94166-0188	941QA-0188	1.88	1.75	2.00
94106-0200	94166-0200	941QA-0200	2.00	1.87	2.12
94106-0212	94166-0212	941QA-0212	2.12	1.93	2.24
94106-0225	94166-0225	941QA-0225	2.25	2.06	2.37
94106-0238	94166-0238	941QA-0238	2.38	2.19	2.50
94106-0250	94166-0250	941QA-0250	2.50	2.31	2.62
94106-0256	94166-0256	941QA-0256	2.56	2.37	2.68
94106-0262	94166-0262	941QA-0262	2.62	2.43	2.74
94106-0275	94166-0275	941QA-0275	2.75	2.56	2.87
94106-0288	94166-0288	941QA-0288	2.88	2.66	2.97
94106-0300	94166-0300	941QA-0300	3.00	2.78	3.09
94106-0312	94166-0312	941QA-0312	3.12	2.90	3.21
94106-0325	94166-0325	941QA-0325	3.25	3.03	3.34
94106-0350	94166-0350	941QA-0350	3.50	3.28	3.59
94106-0375	94166-0375	941QA-0375	3.75	3.53	3.84
94106-0400	94166-0400	941QA-0400	4.00	3.78	4.09
94106-0425	94166-0425	941QA-0425	4.25	4.03	4.34
94106-0450	94166-0450	941QA-0450	4.50	4.28	4.59
94106-0475	94166-0475	941QA-0475	4.75	4.53	4.84
94106-0500	94166-0500	941QA-0500	5.00	4.78	5.09
94106-0525	94166-0525	941QA-0525	5.25	5.03	5.34
94106-0550	94166-0550	941QA-0550	5.50	5.28	5.59
94106-0575	94166-0575	941QA-0575	5.75	5.53	5.84
94106-0600	94166-0600	941QA-0600	6.00	5.78	6.09
94106-0650	94166-0650	941QA-0650	6.50	6.28	6.59
94106-0700	94166-0700	941QA-0700	7.00	6.78	7.09
94106-0750	94166-0750	941QA-0750	7.50	7.28	7.59

S = Stock Items



Now stocking Zinc Plated and Stainless Steel T-Bolt and Locknut Clamp sizes for quick shipment!

When performance is critical – specify Clampco T-Bolt Band Clamps!

Clampco stock T-Bolt Band Clamps feature all 300 series stainless steel bands and trunnions.

Hardware options include:

- Zinc Plated (1/4-28 T-Bolts and Locknuts)
- Stainless Steel (1/4-28 T-Bolts and Locknuts)
- Additional Fastener Sizes and Materials Available

How to order:

Measure the O.D. of your final hose assembly. Select the T-Bolt Band Clamp with the closest nominal diameter.

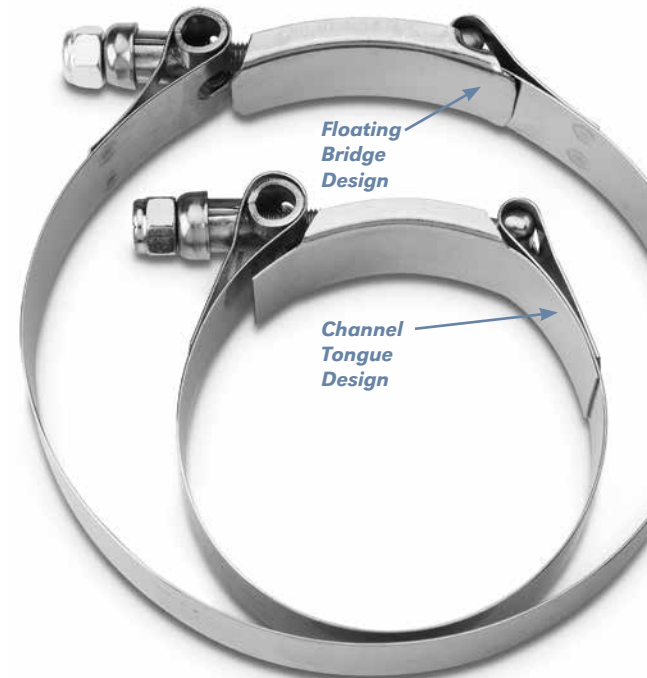

NOTE:

See page 12 for Stock Marine Grade Clamps.

T-BOLT BAND CLAMPS

Made-to-Order

Clampco has manufactured thousands of different clamp styles. Every style reflects a different application requirement. For example, some T-Bolt Clamps are manufactured with permanent latches and heavier gauge stainless steel for tough applications. Others are made with quick release latches for ease of assembly and disassembly. With a wide range of standard latches, hardware and bands, Clampco can meet the most complicated and demanding clamp requirements.

Our catalog will walk you through the process of determining the right clamp for your application. Utilizing the Made-to-Order function on our Clampco website, you can easily develop a product description code for your application.



How to Determine your T-Bolt Band Clamp Description Code

Clampco's description code contains 5 segments, each representing a different part of the clamp. Below is a sample description code:

C410-C-75-450-S

It's easy to create your made-to-order T-Bolt Band Clamp description code, just follow these 5 easy steps:

1. Determine Latch Style Code

C410-C-75-450-S

2. Determine Bolt Code

C410-C-75-450-S

3. Determine Band Width Code

C410-C-75-450-S

4. Determine Band Diameter Code

C410-C-75-450-S

5. Determine Nut, Knob, or T-Handle Code

C410-C-75-450-S

CLAMPSCO LATCH STYLES



T-BOLT LATCH

The Clampco T-Bolt Latch is used for permanent or semi-permanent applications and/or safety on pressurized systems. The T-Bolt Latch is our most economical latch.



QUICK RELEASE LATCH

The Clampco Quick Release Latch is used for ease of disassembly and is required where the ability to replace bolts is desired.



SADDLE QUICK RELEASE LATCH

The Saddle Quick Release Latch is also used for ease of disassembly and where the ability to replace bolts is desired. It is not recommended for diameters larger than 10 in. due to trunnion/band interference.



LIGHT-DUTY OVER CENTER LATCH

The Light-Duty Over Center Latch is used on applications that require frequent assembly or disassembly. No tools are required for opening and closing the clamp after initial installation. This latch style is ideal for light-duty applications on small diameters and requires a 3/16 in. diameter T-Bolt. Uncaptured T-Bolt head standard. Captured T-Bolt head offered as an option.
(Note: Not for use on pressurized V-Band applications.)



MEDIUM-DUTY OVER CENTER LATCH

The Medium-Duty Over Center Latch is well suited for heavier applications and on larger diameters. No tools are required for opening and closing the clamp after initial installation. It is available with either a 1/4 in. or 5/16 in. diameter T-Bolt. Uncaptured T-Bolt head standard. Captured T-Bolt head offered as an option.
(Note: Minimum Band Width - 7/8 in.)
(Note: Not for use on pressurized V-Band applications.)



HEAVY-DUTY OVER CENTER LATCH

The Heavy-Duty Over Center Latch is well suited for heavy-duty applications and large diameters. It is available with a 3/8 in. diameter T-Bolt.
(Note: Minimum Band Width - 1-1/4 in.)
(Note: Not for use on pressurized V-Band applications.)

SPECIFICATIONS

1. DETERMINE LATCH STYLE CODE

C410-c-75-450-S (Sample Description Code)

Stainless steel band material: 301, 302, 304 1/4 hard or 1/2 hard. UNF thread form may be substituted without prior notice.

T-BOLT LATCH

ENGLISH (inches)							METRIC (millimeters)					
CODE	T-BOLT SIZE	MIN. NOMINAL DIAMETER	BAND THICKNESS	ADJUSTABLE RANGE		TOTAL DIAMETRICAL ADJUSTMENT	T-BOLT SIZE	MIN. NOMINAL DIAMETER	BAND THICKNESS	ADJUSTABLE RANGE		TOTAL DIAMETRICAL ADJUSTMENT
				PLUS	MINUS					PLUS	MINUS	
C310	10-32 UNJF 2.25 LG.	1.25	0.025	0.03	0.14	0.17	57.10 LG.	31.50	0.63	0.76	3.50	4.30
C311	10-32 UNJF 2.25 LG.	3.00	0.025	0.08	0.26	0.34	57.10 LG.	76.20	0.63	2.00	6.60	8.60
C410	1/4-28 UNJF 2.75 LG.	1.25	0.025	0.09	0.22	0.31	69.80 LG.	31.50	0.63	2.20	5.50	7.80
C412	1/4-28 UNJF 3.50 LG.	3.50	0.025	0.15	0.50	0.65	88.90 LG.	88.90	0.63	3.80	12.70	16.50
C510	5/16-24 UNJF 3.50 LG.	3.00	0.040	0.09	0.22	0.31	88.90 LG.	76.20	1.01	2.20	5.50	7.80
C511	5/16-24 UNJF 4.00 LG.	6.00	0.050	0.15	0.46	0.61	101.60 LG.	152.40	1.27	3.80	11.60	15.40
C610	3/8-16 UNC 4.00 LG.	8.00	0.062	0.22	0.32	0.54	101.60 LG.	203.20	1.57	5.50	8.10	13.70

C310 & C311: Light-Duty Applications / C410 & C412: Medium-Duty Applications / C510 & C511: Heavy-Duty Applications / C610: Extra Heavy-Duty Applications

QUICK RELEASE LATCH

ENGLISH (inches)							METRIC (millimeters)					
CODE	T-BOLT SIZE	MIN. NOMINAL DIAMETER	BAND THICKNESS	ADJUSTABLE RANGE		TOTAL DIAMETRICAL ADJUSTMENT	T-BOLT SIZE	MIN. NOMINAL DIAMETER	BAND THICKNESS	ADJUSTABLE RANGE		TOTAL DIAMETRICAL ADJUSTMENT
				PLUS	MINUS					PLUS	MINUS	
C320	10-32 UNJF 2.25 LG.	2.00	0.025	0.03	0.14	0.17	57.10 LG.	50.80	0.63	0.76	3.50	4.30
C321	10-32 UNJF 2.25 LG.	3.00	0.025	0.08	0.26	0.34	57.10 LG.	76.20	0.63	2.00	6.60	8.60
C420	1/4-28 UNJF 2.75 LG.	1.50	0.025	0.09	0.22	0.31	69.80 LG.	38.10	0.63	2.20	5.50	7.80
C422	1/4-28 UNJF 3.50 LG.	3.50	0.025	0.15	0.50	0.65	88.90 LG.	88.90	0.63	3.80	12.70	16.50
C520	5/16-24 UNJF 3.50 LG.	3.50	0.040	0.09	0.22	0.31	88.90 LG.	88.90	1.01	2.20	5.50	7.80
C521	5/16-24 UNJF 4.00 LG.	6.50	0.050	0.15	0.46	0.61	101.60 LG.	165.10	1.27	3.80	11.60	15.40
C620	3/8-16 UNC 4.00 LG.	6.50	0.062	0.22	0.32	0.54	101.60 LG.	165.10	1.57	5.50	8.10	13.70
C621	3/8-16 UNC 4.50 LG.	6.50	0.062	0.37	0.32	0.69	114.30 LG.	165.10	1.57	9.30	8.10	17.50

C320 & C321: Light-Duty Applications / C420 & C422: Medium-Duty Applications / C520 & C521: Heavy-Duty Applications / C620 & C621: Extra Heavy-Duty Applications

SADDLE QUICK RELEASE LATCH

ENGLISH (inches)							METRIC (millimeters)					
CODE	T-BOLT SIZE	MIN. NOMINAL DIAMETER	BAND THICKNESS	ADJUSTABLE RANGE		TOTAL DIAMETRICAL ADJUSTMENT	T-BOLT SIZE	MIN. NOMINAL DIAMETER	BAND THICKNESS	ADJUSTABLE RANGE		TOTAL DIAMETRICAL ADJUSTMENT
				PLUS	MINUS					PLUS	MINUS	
C330	10-32 UNJF 2.25 LG.	2.00	0.025	0.03	0.14	0.17	57.10 LG.	50.80	0.63	0.76	3.50	4.30
C331	10-32 UNJF 2.25 LG.	3.00	0.025	0.08	0.26	0.34	57.10 LG.	76.20	0.63	2.00	6.60	8.60
C430	1/4-28 UNJF 2.75 LG.	1.25	0.025	0.09	0.22	0.31	69.80 LG.	31.70	0.63	2.20	5.50	7.80
C432	1/4-28 UNJF 3.50 LG.	3.50	0.025	0.15	0.50	0.65	88.90 LG.	88.90	0.63	3.80	12.70	16.50
C530	5/16-24 UNJF 3.50 LG.	3.50	0.040	0.09	0.22	0.31	88.90 LG.	88.90	1.01	2.20	5.50	7.80
C531	5/16-24 UNJF 4.00 LG.	6.50	0.050	0.15	0.46	0.61	101.60 LG.	165.10	1.27	3.80	11.60	15.40

C330 & C331: Light-Duty Applications / C430 & C432: Medium-Duty Applications / C530 & C531: Heavy-Duty Applications

LIGHT-DUTY OVER CENTER LATCH

ENGLISH (inches)							METRIC (millimeters)					
CODE	T-BOLT SIZE	MIN. NOMINAL DIAMETER	BAND THICKNESS	ADJUSTABLE RANGE		TOTAL DIAMETRICAL ADJUSTMENT	T-BOLT SIZE	MIN. NOMINAL DIAMETER	BAND THICKNESS	ADJUSTABLE RANGE		TOTAL DIAMETRICAL ADJUSTMENT
				PLUS	MINUS					PLUS	MINUS	
C360	10-32 UNJF 2.25 LG.	2.50	0.025	0.08	0.26	0.34	57.10 LG.	63.50	0.63	2.00	6.60	8.60
C370	10-32 UNJF 2.25 LG.	2.50	0.025	0.08	0.26	0.34	57.10 LG.	63.50	0.63	2.00	6.60	8.60

C360 & C370: Light-Duty Applications / C360: Captured T-Bolt Head / C370: Uncaptured T-Bolt Head.
See page 31 for photos and safety features.

MEDIUM-DUTY OVER CENTER LATCH

ENGLISH (inches)							METRIC (millimeters)					
CODE	T-BOLT SIZE	MIN. NOMINAL DIAMETER	BAND THICKNESS	ADJUSTABLE RANGE		TOTAL DIAMETRICAL ADJUSTMENT	T-BOLT SIZE	MIN. NOMINAL DIAMETER	BAND THICKNESS	ADJUSTABLE RANGE		TOTAL DIAMETRICAL ADJUSTMENT
				PLUS	MINUS					PLUS	MINUS	
C490	1/4-28 UNJF 2.75 LG.	4.68	0.025	0.09	0.22	0.31	69.80 LG.	118.80	0.63	2.20	5.50	7.80
C492	1/4-28 UNJF 3.50 LG.	4.68	0.025	0.15	0.50	0.65	88.90 LG.	118.80	0.63	3.80	12.70	16.50
C590	15/16-24 UNJF 3.50 LG.	5.50	0.040	0.09	0.22	0.31	88.90 LG.	139.70	1.01	2.20	5.50	7.80
C592	15/16-24 UNJF 4.00 LG.	5.50	0.050	0.15	0.46	0.61	101.60 LG.	139.70	1.27	3.80	11.60	15.40

C490 & C492: Medium-Duty Applications / C590 & C592: Heavy-Duty Applications
Styles listed above include Uncaptured T-Bolt Heads. Captured T-Bolt Head styles are available upon request.
See page 31 for photos and safety features.

HEAVY-DUTY OVER CENTER LATCH

ENGLISH (inches)							METRIC (millimeters)					
CODE	T-BOLT SIZE	MIN. NOMINAL DIAMETER	BAND THICKNESS	ADJUSTABLE RANGE		TOTAL DIAMETRICAL ADJUSTMENT	T-BOLT SIZE	MIN. NOMINAL DIAMETER	BAND THICKNESS	ADJUSTABLE RANGE		TOTAL DIAMETRICAL ADJUSTMENT
				PLUS	MINUS					PLUS	MINUS	
C690	3/8-16 UNC 4.50 LG.	10.00	0.062	0.28	0.28	0.56	114.30	254.00	1.57	7.10	7.10	14.20

C690: Extra Heavy-Duty Applications
See page 31 for photos and safety features.





T-BOLT BAND CLAMPS

Made-to-Order

2. DETERMINE BOLT CODE

C410-C-75-450-S (Sample Description Code)

Clampco offers the following bolts as standard options. Other bolt materials and thread sizes are available upon request. Some bolts may be bent for small diameter applications.

CODE	BOLT DESCRIPTION	THREAD SIZE
C		4037 Alloy Heat Treated to 125,000 to 145,000 psi, Zinc Plated,
		10-32
		1/4-28
		M6 X 1
		5/16-24
		3/8-16
N		18-8 Stainless Steel (302 or 305)
		10-32
		1/4-20
		1/4-28
		5/16-18
		5/16-24
M		431, 420 or 410 Stainless Steel Heat Treated to 140,000 to 160,000 psi
		10-32
		1/4-28
		M6 X 1
		5/16-24
		M8 X 1.25
A		A286 Stainless Steel, 130,000 psi minimum
		10-32
W		316 Stainless Steel
		1/4-28
		M6 X 1
		M8 X 1.25

*Inquire about additional materials and coatings

Bolt Performance and Torque Chart

THREAD SIZE	BOLT MATERIAL	MAXIMUM	
		RECOMMENDED TORQUE IN. - LBS.	ULTIMATE TENSILE STRENGTH LBS.
10-32	300 Series Stainless Steel	50	1815
10-32	Type 410, 420 or 431 Stainless Steel	66	2390
10-32	Type A286 Stainless Steel	65	2390
10-32	Plated Alloy Steel	65	2390
1/4-20	300 Series Stainless Steel	75	3322
1/4-28	300 Series Stainless Steel	75	3322
M6 X 1	300 Series Stainless Steel	75	3322
1/4-28	Type 410, 420 or 431 Stainless Steel	90	4370
M6 X 1	Type 410, 420 or 431 Stainless Steel	90	4370
1/4-28	Type A286 Stainless Steel	90	4370
1/4-28	Plated Alloy Steel	90	4370
M6 X 1	Plated Alloy Steel	90	4370
5/16-18	300 Series Stainless Steel	180	5320
5/16-24	300 Series Stainless Steel	180	5320
M8 X 1.25	300 Series Stainless Steel	180	5320
5/16-24	Type 410, 420 or 431 Stainless Steel	240	7000
M8 X 1.25	Type 410, 420 or 431 Stainless Steel	240	7000
5/16-24	Type A286 Stainless Steel	240	7000
5/16-24	Plated Alloy Steel	240	7000
3/8-16	300 Series Stainless Steel	390	7100
3/8-16	Plated Alloy Steel	480	9350
1/2-13	Plated Alloy Steel	550	17200

300 series stainless steel bolt strength based on 95,000 psi minimum tensile strength. Type 410-431 stainless steel bolt strength based on 125,000 psi minimum tensile strength. Type A286 stainless steel bolt strength based on 125,000 psi minimum tensile strength. Plated alloy steel bolt strength based on 125,000 psi minimum tensile strength. Torque coupling or band to a level where joints are properly closed. Maximum torque levels are not required for proper joint function.

3. DETERMINE BAND WIDTH CODE

C410-C-75-450-S (Sample Description Code)

Clampco clamps are available with a wide variety of band widths. Locate the band width required, then verify availability based on the Latch Style Code you determined from Step 1 on page 7.



ENGLISH (inches)		
CODE	LATCH STYLE CODE FROM PAGE 7	BAND WIDTH
62	C310, C311, C320, C321, C330, C331, C360, C370	0.625
75	C310, C311, C320, C321, C330, C331, C360, C370, C410, C412, C420, C422, C430, C432	0.750
88	C310, C311, C320, C321, C330, C331, C360, C370, C410, C412, C420, C422, C430, C432, C490, C492, C510, C511, C520, C521, C530, C531, C590, C592	0.875
100	C310, C311, C320, C321, C330, C331, C360, C370, C410, C412, C420, C422, C430, C432, C490, C492, C510, C511, C520, C521, C530, C531, C590, C592	1.000
112	C410, C412, C420, C422, C430, C432, C490, C492, C510, C511, C520, C521, C530, C531, C590, C592	1.125
125	C410, C412, C420, C422, C430, C432, C490, C492, C510, C511, C520, C521, C530, C531, C590, C592, C610, C620, C621, C690	1.250
138	C410, C412, C420, C422, C430, C432, C490, C492, C510, C511, C520, C521, C530, C531, C590, C592, C610, C620, C621, C690	1.375
150	C410, C412, C420, C422, C430, C432, C490, C492, C510, C511, C520, C521, C530, C531, C590, C592, C610, C620, C621, C690	1.500
162	C510, C511, C520, C521, C530, C531, C590, C592, C610, C620, C621, C690	1.625
175	C510, C511, C520, C521, C530, C531, C590, C592, C610, C620, C621, C690	1.750
188	C510, C511, C520, C521, C530, C531, C590, C592, C610, C620, C621, C690	1.875
200	C510, C511, C520, C521, C530, C531, C590, C592, C610, C620, C621, C690	2.000
212	C510, C511, C520, C521, C530, C531, C590, C592, C610, C620, C621, C690	2.125
225	C510, C511, C520, C521, C530, C531, C590, C592, C610, C620, C621, C690	2.250
238	C510, C511, C520, C521, C530, C531, C590, C592, C610, C620, C621, C690	2.375
250	C510, C511, C520, C521, C530, C531, C590, C592, C610, C620, C621, C690	2.500
262	C510, C511, C520, C521, C530, C531, C590, C592, C610, C620, C621, C690	2.625
275	C510, C511, C520, C521, C530, C531, C590, C592, C610, C620, C621, C690	2.750
288	C510, C511, C520, C521, C530, C531, C590, C592, C610, C620, C621, C690	2.875
300	C510, C511, C520, C521, C530, C531, C590, C592, C610, C620, C621, C690	3.000

SPECIFICATIONS

4. DETERMINE BAND DIAMETER CODE

C410-C-75-**450**-S (Sample Description Code)

The nominal band diameter is based on the outside diameter (O.D.) of the final hose or tube assembly. The last 2 digits of the code are represented as a two place decimal number without the decimal point.

For Example:

4 1/2 in. = 4.50 in. = 450

5 in. = 5.00 in. = 500

6 3/8 in. = 6.375 in. = 638

24 9/16 in. = 24.562 in. = 2456

When starting with a metric unit, convert millimeters to inches rounded to two decimal places and then drop the decimal point.

For Example:

60 mm = (60 mm/25.4) = 2.36 in. = 236

Note: Minimum nominal diameter is determined by the latch style you have chosen. Refer to Latch Style Code from Step 1 on page 7 for minimum nominal diameter requirements.

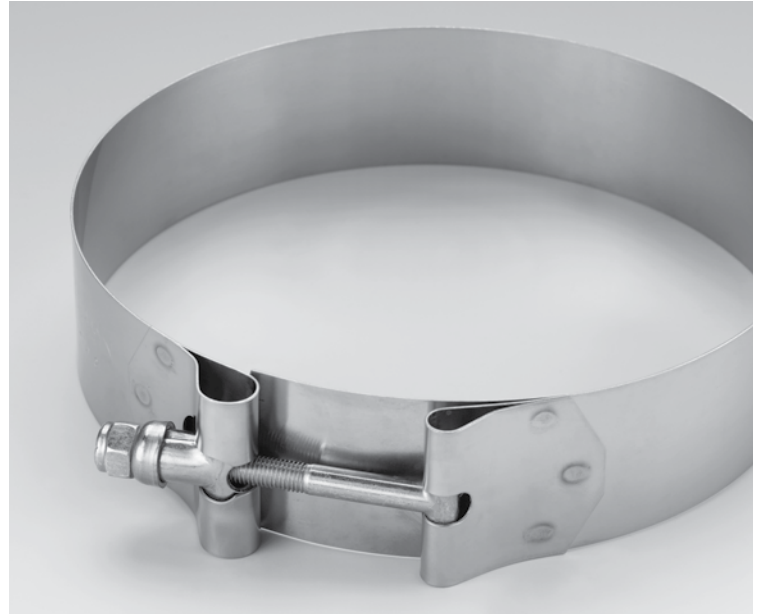















NOTE: See page 34 for additional information on how to determine the nominal size for your hose clamp application.

5. DETERMINE NUT, KNOB, OR T-HANDLE CODE

C410-C-75-450-**S** (Sample Description Code)

Clampco provides the following Nuts, Knobs and T-Handles as standard options. Choose the Nut, Knob or T-Handle that is best suited to your application, or contact our sales department with your special request.

CODE	KNOB AND T-HANDLE DESCRIPTION	THREAD SIZE
K	 Knob for hand tightening, plastic with Brass insert, 1 in. long	10-32 1/4-28
K1	 Knob for hand tightening, plastic with Brass insert, 1.75 in. long	1/4-20 1/4-28
T	 T-Handle for hand tightening, Steel/Zinc Plated, 3 in. long	10-32 1/4-28 5/16-24
T2	 T-Handle for hand tightening, Steel/Zinc Plated, 2.125 in. long	1/4-28
T7	 T-Handle for hand tightening, 400 series Stainless Steel, 3 in. long	1/4-28 5/16-24
T9	 T-Handle for hand tightening, 300 series Stainless Steel, 3 in. long	5/16-24
T14	 T-Handle for hand tightening, 300 series Stainless Steel, 3 in. long	1/4-28

CODE	NUT DESCRIPTION	THREAD SIZE	TEMP RATING	SELF-LOCKING
S	 Steel, self-locking, nylon insert, Zinc Plated	10-32 1/4-28 5/16-24 M6 X 1	250° F	Yes
S1	 All metal, Steel, self-locking, collar or short beam design, Silver Plated	10-32 1/4-28 5/16-24 3/8-16	550° F	Yes
S2	 All metal, 18-8 Stainless Steel*, self-locking, collar or short beam design, Silver Plated	10-32 1/4-28 5/16-24 3/8-16	800° F	Yes
S3	 All metal, 347 Stainless Steel*, self-locking, collar or short beam design, Silver Plated	10-32 1/4-28 5/16-24	1200° F	Yes
S4	 18-8 Stainless Steel, self-locking, nylon insert, Silver Plated	10-32 1/4-28 5/16-24 3/8-16	250° F	Yes
S6	 All metal, 347 Stainless Steel, self-locking, long beam design, Silver Plated	10-32 1/4-28	1200° F	Yes
S14	 316 Stainless Steel, self-locking, nylon insert, Silver Plated	1/4-28 5/16-24 M6 X 1 M8 X 1.25	250° F	Yes
S22	 All metal, 300 series Stainless Steel, self-locking, Silver Plated, Emuge Style Thread design	M8 X 1.25	800° F	Yes
H	 Stainless Steel Hex Nut, Silver Plated	10-32 1/4-28 5/16-24 3/8-16 M6 X 1 M8 X 1.25	800° F	No
H6	 Steel Hex Nut, Zinc Plated	10-32 1/4-28 5/16-24 3/8-16	-	No
H8	 Brass Hex Nut	10-32 1/4-28 5/16-24 3/8-16	-	No

NOTE:
See pages 30 and 31 for additional Knob and T-Handle information.

*We reserve the right to substitute with A286 stainless steel and/or other equivalent locknuts unless otherwise specified.

T-BOLT BAND CLAMPS

Spring-Loaded Clamps



Now stocking popular Spring-Loaded Clamp sizes for quick shipment!

The Adjustable Advantage

Clampco Spring-Loaded Clamps are designed to compensate for fluctuations in all types of hose line assemblies. When temperature and/or pressure changes cause hose lines to expand or contract, Clampco Spring-Loaded Clamps adjust accordingly to provide constant band tension.

Several additional design advantages make Clampco clamps the preferred solution for critical applications. With 300 series stainless steel bands and trunnions, Clampco Spring-Loaded Clamps provide high strength and corrosion resistance. Solid bands prevent hose extrusions, and rounded band edges protect soft hose materials. Plus, a low amount of installation torque results in high band tension. Band tension, not installation torque, is what ultimately produces desired clamping force.

Clampco now offers optional material and coating options for your high corrosion and heat applications.



**CLAMP
CUSTOM**

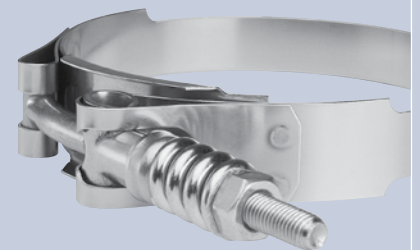

Custom Order

Are you looking for something special? For example, this clamp has a light-duty spring and a notched band. Contact Clampco with your hose application requirements. Our sales engineers will help you design a Spring-Loaded Clamp for your specific application.

We Customize. Call Today.

SPECIFICATIONS

FEATURES:

Clampco Spring-Loaded Clamps are manufactured with the following components:

- 300 Series Stainless Band, Trunion and Floating Bridge
- Band 0.025 in. Thick x 0.75 in. Wide
- 1/4-28 Zinc Plated Hardware and Springs



94331 & 94143 Series LIGHT-DUTY

Recommended Install Torque
40-45 in.-lbs.

Spring rate of 1900 lbs./in.
capable of generating a load of
300 lbs.

HOW TO ORDER:

Measure the outside diameter (O.D.) of your final hose assembly. Locate the Spring-Loaded Clamp part number with the closest nominal diameter. Recommended installation torque for both light- and heavy-duty clamps is 40-45 in.-lbs.

See page 34 for additional information on how to determine the nominal size for your hose clamp application.

Other sizes, styles, and materials are available upon request.



94158 Series HEAVY-DUTY

Recommended Install Torque
40-45 in.-lbs.

Spring rate of 1357 lbs./in.
capable of generating a load of
377 lbs.

ENGLISH (inches)			
PART NUMBER	NOMINAL DIAMETER	MINIMUM DIAMETER	MAXIMUM DIAMETER
94331-0125	1.25	1.12	1.32
94331-0138	1.38	1.26	1.45
94331-0162	1.62	1.50	1.69
94143-0194	1.94	1.82	2.12
94143-0225	2.25	2.06	2.36
94143-0238	2.38	2.19	2.49
94143-0244	2.44	2.25	2.55
94143-0250	2.50	2.31	2.61
94143-0256	2.56	2.37	2.67
94143-0275	2.75	2.56	2.86
94143-0278	2.78	2.59	2.89
94143-0281	2.81	2.62	2.92
94143-0288	2.88	2.69	2.99
Ⓢ 94143-0300	3.00	2.78	3.08
94143-0302	3.02	2.80	3.14
94143-0316	3.16	2.94	3.24
94143-0318	3.18	2.96	3.26
Ⓢ 94143-0325	3.25	3.03	3.33
94143-0328	3.28	3.06	3.36
94143-0330	3.30	3.08	3.38
Ⓢ 94143-0337	3.37	3.15	3.45
Ⓢ 94143-0344	3.44	3.22	3.52
94143-0348	3.48	3.26	3.56
94143-0350	3.50	3.28	3.58
94143-0353	3.53	3.31	3.61
94143-0356	3.56	3.34	3.64
94143-0375	3.75	3.53	3.83
94143-0378	3.78	3.56	3.86
94143-0385	3.85	3.63	3.93
94143-0400	4.00	3.78	4.08
94143-0411	4.11	3.89	4.19
Ⓢ 94143-0425	4.25	4.03	4.33
Ⓢ 94143-0428	4.28	4.06	4.36
Ⓢ 94143-0450	4.50	4.28	4.58
94143-0475	4.75	4.53	4.83
94143-0500	5.00	4.78	5.08
94143-0525	5.25	5.03	5.33
94143-0550	5.50	5.28	5.58
94143-0556	5.56	5.34	5.64
94143-0562	5.62	5.40	5.70
94143-0600	6.00	5.78	6.08
94143-0605	6.05	5.83	6.13
94143-0610	6.10	5.88	6.18
94143-0625	6.25	6.03	6.33
94143-0647	6.47	6.25	6.55
94143-0660	6.60	6.38	6.68
94143-0700	7.00	6.78	7.08
94143-0750	7.50	7.28	7.58
94143-0760	7.60	7.38	7.68
94143-0762	7.62	7.40	7.70
94143-0766	7.66	7.44	7.74
94143-0772	7.72	7.50	7.80
94143-0775	7.75	7.53	7.83
94143-0850	8.50	8.28	8.59
94143-0872	8.72	8.50	8.80

Ⓢ = Stock Items

ENGLISH (inches)			
PART NUMBER	NOMINAL DIAMETER	MINIMUM DIAMETER	MAXIMUM DIAMETER
94158-0234	2.34	2.11	4.46
94158-0284	2.84	2.62	2.96
Ⓢ 94158-0325	3.25	3.10	3.41
94158-0375	3.75	3.53	3.88
94158-0378	3.78	3.56	3.91
94158-0400	4.00	3.78	4.13
94158-0411	4.11	3.89	4.24
Ⓢ 94158-0428	4.28	4.12	4.43
Ⓢ 94158-0450	4.50	4.28	4.63
94158-0600	6.00	5.78	6.13
94158-0650	6.50	6.35	6.66

Ⓢ = Stock Items



*Now stocking popular
Spring-Loaded Clamp
sizes for quick shipment!*



T-BOLT BAND CLAMPS

Marine Grade Clamps

Ready to Deliver!

Corrosion Safeguard

Clampco Products manufactures and stocks Marine Grade 316 Stainless Steel T-Bolt Band Clamps. The 316 T-Bolt Band Clamps offer better corrosion resistance than the standard 301, 302, and 304 T-Bolt Band Clamps. Because 316 stainless steel performs well in saltwater applications, 316 T-Bolt Band Clamps are commonly installed on marine engine and exhaust systems. Other typical applications include water treatment and sewage systems, pool fittings, telecommunication devices, and food and pharmaceutical processing equipment.

Clampco currently stocks the following Marine Grade 316 Stainless Steel T-Bolt Band Clamps. Other sizes and styles are available upon customer request. Add electropolish finishing for additional corrosion resistance.

941YL Series

316 Stainless Steel Band, Trunnion, 1/4-28 Bolt and Locknut
Band 0.025 in. Thick x 0.75 in. Wide

316 STAINLESS STEEL CLAMPS

Maximum Torque 75 in.-lbs. (dry)

ENGLISH (inches)			
PART NUMBER	NOMINAL DIAMETER	MINIMAL DIAMETER	MAXIMUM DIAMETER
Ⓢ 941YL-0125	1.25	1.09	1.25
Ⓢ 941YL-0150	1.50	1.35	1.50
Ⓢ 941YL-0162	1.62	1.46	1.62
Ⓢ 941YL-0175	1.75	1.59	1.87
Ⓢ 941YL-0200	2.00	1.84	2.13
Ⓢ 941YL-0225	2.25	2.03	2.38
Ⓢ 941YL-0250	2.50	2.28	2.63
Ⓢ 941YL-0275	2.75	2.53	2.88
Ⓢ 941YL-0300	3.00	2.78	3.13
Ⓢ 941YL-0350	3.50	3.28	3.63
Ⓢ 941YL-0375	3.75	3.53	3.88
Ⓢ 941YL-0400	4.00	3.78	4.13
Ⓢ 941YL-0425	4.25	4.03	4.38
Ⓢ 941YL-0450	4.50	4.28	4.63
Ⓢ 941YL-0475	4.75	4.53	4.88
Ⓢ 941YL-0500	5.00	4.78	5.13
Ⓢ 941YL-0550	5.50	5.28	5.63
Ⓢ 941YL-0600	6.00	5.78	6.13
Ⓢ 941YL-0650	6.50	6.28	6.63
Ⓢ 941YL-0700	7.00	6.78	7.13

Additional Custom Sizes Available

Ⓢ = Stock Items



**CLAMPSCO
CUSTOM**



Custom Order

Clampco is well known for its ability to manufacture custom orders. Some custom orders include different hardware, band thicknesses, and band widths. This picture shows a clamp with a floating bridge under the latch rather than a flat tongue. If you don't see what you need in our catalog, contact our sales department to discuss your special requirements. Custom orders are nothing new to Clampco!

We Customize. Call Today.

T-BOLT BAND CLAMPS

Military MS21920 Clamps

Approved by the U.S. Department of Defense

Clampco Products is one of the few manufacturing companies in the clamp industry to qualify as a U.S. Government vendor. Clampco has been supplying the U.S. Government directly and through qualified distributors since 1982 and is listed on the Qualified Parts List (QPL) for MS21920 Clamps.

Manufactured in accordance with MIL-DTL-8783. This specification covers flat band, T-Bolt latch clamps and flat band, quick-release latch clamps used in various aircraft installations of duct, hose and flex tubing.



MS21920 Series
Band Width = 0.625 in.
T-BOLT LATCH STYLE

Maximum Torque 65 in.-lbs.



MS21920R Series
Band Width = 0.625 in.
QUICK RELEASE LATCH STYLE

Maximum Torque 65 in.-lbs.

ENGLISH (inches)						
GOVERNMENT DESIGNATION	PART NUMBER	NOMINAL DIAMETER	MINIMUM DIAMETER	MAXIMUM DIAMETER	T-BOLT LENGTH	MAX. WEIGHT (LBS)
MS21920-20	93172-0238	2.38	2.25	2.50	2.25	0.139 REF
MS21920-21	93172-0250	2.50	2.38	2.62	2.25	0.143 REF
MS21920-22	93172-0262	2.62	2.50	2.75	2.25	0.143 REF
MS21920-23	93172-0281	2.81	2.62	2.88	2.25	0.146 REF
MS21920-24	93172-0288	2.88	2.75	3.00	2.25	0.146 REF
MS21920-25	93172-0300	3.00	2.88	3.12	2.25	0.150 REF
MS21920-26	93172-0312	3.12	3.00	3.25	2.25	0.150 REF
MS21920-27	93172-0325	3.25	3.12	3.38	2.25	0.153 REF
MS21920-28	93172-0338	3.38	3.25	3.50	2.25	0.153 REF
MS21920-29	93172-0350	3.50	3.38	3.62	2.25	0.157 REF
MS21920-30	93172-0362	3.62	3.50	3.75	2.25	0.157 REF
MS21920-32	93173-0381	3.81	3.62	4.00	2.50	0.164 REF
MS21920-33	93173-0394	3.94	3.75	4.12	2.50	0.164 REF
MS21920-34	93173-0406	4.06	3.88	4.25	2.50	0.167 REF
MS21920-35	93173-0419	4.19	4.00	4.38	2.50	0.167 REF
MS21920-36	93173-0431	4.31	4.12	4.50	2.50	0.171 REF
MS21920-37	93173-0444	4.44	4.25	4.62	2.50	0.171 REF
MS21920-38	93173-0456	4.56	4.38	4.75	2.50	0.174 REF
MS21920-39	93173-0469	4.69	4.50	4.88	2.50	0.174 REF
MS21920-40	93173-0481	4.81	4.62	5.00	2.50	0.178 REF
MS21920-41	93173-0494	4.94	4.75	5.12	2.50	0.178 REF
MS21920-42	93173-0506	5.06	4.88	5.25	2.50	0.181 REF
MS21920-43	93173-0519	5.19	5.00	5.38	2.50	0.181 REF
MS21920-44	93173-0531	5.31	5.12	5.50	2.50	0.185 REF
MS21920-45	93173-0544	5.44	5.25	5.62	2.50	0.185 REF
MS21920-46	93173-0556	5.56	5.38	5.75	2.50	0.188 REF
MS21920-47	93173-0569	5.69	5.50	5.88	2.50	0.188 REF
MS21920-48	93173-0581	5.81	5.62	6.00	2.50	0.192 REF
MS21920-49	93173-0594	5.94	5.75	6.12	2.50	0.192 REF
MS21920-50	93173-0606	6.06	5.88	6.25	2.50	0.195 REF
MS21920-51	93173-0619	6.19	6.00	6.38	2.50	0.195 REF
MS21920-52	93173-0631	6.31	6.12	6.50	2.50	0.199 REF
MS21920-53	93173-0644	6.44	6.25	6.62	2.50	0.199 REF
MS21920-54	93173-0657	6.57	6.38	6.75	2.50	0.202 REF
MS21920-55	93173-0669	6.69	6.50	6.88	2.50	0.202 REF
MS21920-56	93173-0681	6.81	6.62	7.00	2.50	0.202 REF
MS21920-57	93173-0694	6.94	6.75	7.12	2.50	0.205 REF
MS21920-58	93173-0706	7.06	6.88	7.25	2.50	0.205 REF
MS21920-59	93173-0719	7.19	7.00	7.38	2.50	0.209 REF
MS21920-60	93173-0731	7.31	7.12	7.50	2.50	0.212 REF
MS21920-61	93173-0744	7.44	7.25	7.62	2.50	0.212 REF
MS21920-64	93174-0764	7.64	7.38	8.00	2.50	0.227 REF
MS21920-66	93174-0793	7.93	7.62	8.25	3.50	0.227 REF
MS21920-68	93174-0818	8.18	7.88	8.50	3.50	0.234 REF
MS21920-70	93174-0843	8.43	8.12	8.75	3.50	0.234 REF
MS21920-72	93174-0869	8.69	8.38	9.00	3.50	0.241 REF
MS21920-74	93174-0893	8.93	8.62	9.25	3.50	0.241 REF
MS21920-76	93174-0919	9.19	8.88	9.50	3.50	0.248 REF
MS21920-78	93174-0943	9.43	9.12	9.75	3.50	0.248 REF
MS21920-80	93174-0969	9.69	9.38	10.00	3.50	0.251 REF

ENGLISH (inches)						
GOVERNMENT DESIGNATION	PART NUMBER	NOMINAL DIAMETER	MINIMUM DIAMETER	MAXIMUM DIAMETER	T-BOLT LENGTH	MAX. WEIGHT (LBS)
MS21920-20R	93275-0238	2.38	2.25	2.50	2.25	0.139 REF
MS21920-21R	93275-0250	2.50	2.38	2.62	2.25	0.143 REF
MS21920-22R	93275-0262	2.62	2.50	2.75	2.25	0.143 REF
MS21920-23R	93275-0281	2.81	2.62	2.88	2.25	0.146 REF
MS21920-24R	93275-0288	2.88	2.75	3.00	2.25	0.146 REF
MS21920-25R	93275-0300	3.00	2.88	3.12	2.25	0.150 REF
MS21920-26R	93275-0312	3.12	3.00	3.25	2.25	0.150 REF
MS21920-27R	93275-0325	3.25	3.12	3.38	2.25	0.153 REF
MS21920-28R	93275-0338	3.38	3.25	3.50	2.25	0.153 REF
MS21920-29R	93275-0350	3.50	3.38	3.62	2.25	0.157 REF
MS21920-30R	93275-0362	3.62	3.50	3.75	2.25	0.157 REF
MS21920-32R	93275-0381	3.81	3.62	4.00	2.50	0.164 REF
MS21920-33R	93275-0394	3.94	3.75	4.12	2.50	0.164 REF
MS21920-34R	93275-0406	4.06	3.88	4.25	2.50	0.167 REF
MS21920-35R	93275-0419	4.19	4.00	4.38	2.50	0.167 REF
MS21920-36R	93275-0431	4.31	4.12	4.50	2.50	0.171 REF
MS21920-37R	93275-0444	4.44	4.25	4.62	2.50	0.171 REF
MS21920-38R	93275-0456	4.56	4.38	4.75	2.50	0.174 REF
MS21920-39R	93275-0469	4.69	4.50	4.88	2.50	0.174 REF
MS21920-40R	93275-0481	4.81	4.62	5.00	2.50	0.178 REF
MS21920-41R	93275-0494	4.94	4.75	5.12	2.50	0.178 REF
MS21920-42R	93275-0506	5.06	4.88	5.25	2.50	0.181 REF
MS21920-43R	93275-0519	5.19	5.00	5.38	2.50	0.181 REF
MS21920-44R	93275-0531	5.31	5.12	5.50	2.50	0.185 REF
MS21920-45R	93275-0544	5.44	5.25	5.62	2.50	0.185 REF
MS21920-46R	93275-0556	5.56	5.38	5.75	2.50	0.188 REF
MS21920-47R	93275-0569	5.69	5.50	5.88	2.50	0.188 REF
MS21920-48R	93275-0581	5.81	5.62	6.00	2.50	0.192 REF
MS21920-49R	93275-0594	5.94	5.75	6.12	2.50	0.192 REF
MS21920-50R	93275-0606	6.06	5.88	6.25	2.50	0.195 REF
MS21920-51R	93275-0619	6.19	6.00	6.38	2.50	0.195 REF
MS21920-52R	93275-0631	6.31	6.12	6.50	2.50	0.199 REF
MS21920-53R	93275-0644	6.44	6.25	6.62	2.50	0.199 REF
MS21920-54R	93275-0657	6.57	6.38	6.75	2.50	0.202 REF
MS21920-55R	93275-0669	6.69	6.50	6.88	2.50	0.202 REF
MS21920-56R	93275-0681	6.81	6.62	7.00	2.50	0.202 REF
MS21920-57R	93275-0694	6.94	6.75	7.12	2.50	0.205 REF
MS21920-58R	93275-0706	7.06	6.88	7.25	2.50	0.205 REF
MS21920-59R	93275-0719	7.19	7.00	7.38	2.50	0.209 REF
MS21920-60R	93275-0731	7.31	7.12	7.50	2.50	0.212 REF
MS21920-61R	93275-0744	7.44	7.25	7.62	2.50	0.212 REF
MS21920-64R	93277-0764	7.64	7.38	8.00	2.50	0.227 REF
MS21920-66R	93277-0793	7.93	7.62	8.25	3.50	0.227 REF
MS21920-68R	93277-0818	8.18	7.88	8.50	3.50	0.234 REF
MS21920-70R	93277-0843	8.43	8.12	8.75	3.50	0.234 REF
MS21920-72R	93277-0869	8.69	8.38	9.00	3.50	0.241 REF
MS21920-74R	93277-0893	8.93	8.62	9.25	3.50	0.241 REF
MS21920-76R	93277-0919	9.19	8.88	9.50	3.50	0.248 REF
MS21920-78R	93277-0943	9.43	9.12	9.75	3.50	0.248 REF
MS21920-80R	93277-0969	9.69	9.38	10.00	3.50	0.251 REF

BARREL HARDWARE CLAMPS

Zinc Plated & Stainless Steel Barrels

Performance Meets Safety

Clampco offers Barrel Hardware Clamps as yet another fastening solution. When space constraints prohibit the use of standard T-Bolt Band Clamps, Barrel Hardware Clamps offer an attractive, low-profile design. With excellent product performance and attractive appearance, Barrel Hardware Clamps are popular components on appearance-driven products such as motorcycle exhaust systems and high-performance race cars. All stainless steel versions can be electro-polished for improved cosmetics.



Because of their design, Barrel Hardware Clamps ease certain installations. For example, as a Barrel Hardware Clamp is tightened, the end of the socket head cap screw moves away, rather than towards, the operator. This feature improves safety by minimizing parts that protrude after installation, and deep socket installation tools are not required.

Clampco Barrel Hardware Clamps are available in diameters as small as 1.12 in., perfect for tight, hard-to-access spaces. Standard materials for the clamps include 300 series stainless steel bands, zinc plated or stainless steel barrel trunnions and nuts, and stainless steel socket head cap screws.



Custom Order

Clampco offers Custom Barrel Hardware Clamps to securely fasten Heavy-Duty On- and Off-Highway applications such as Air/Fluid Tanks and Diesel After-treatment Systems.

Let our experienced Technical Sales Staff assist you on a Custom Design based on your specific product application requirements.

We Customize. Call Today.



SPECIFICATIONS

98050 Series

Narrow Band Width = 0.55 in.

ZINC PLATED BARRELS

Specifications:

- 0.025 in. Thick 300 Series Stainless Band and Tongue
- 10-24 300 Series Stainless Steel SHCS
- Steel/Zinc Plate Barrel Hardware

Maximum Torque 30 in.-lbs.

98054 Series

Narrow Band Width = 0.55 in.

STAINLESS STEEL BARRELS

Specifications:

- 0.025 in. Thick 300 Series Stainless Band and Tongue
- 10-24 300 Series Stainless Steel SHCS
- 300 Series Stainless Barrel Hardware

Maximum Torque 30 in.-lbs.

ENGLISH (inches)				
PART NUMBER	PART NUMBER	NOMINAL DIAMETER	MINIMUM DIAMETER	MAXIMUM DIAMETER
98050-0150	98054-0150	1.50	1.36	1.55
98050-0175	98054-0175	1.75	1.61	1.80
98050-0188	98054-0188	1.88	1.74	1.93
98050-0200	98054-0200	2.00	1.86	2.05
98050-0212	98054-0212	2.12	1.98	2.17
98050-0225	98054-0225	2.25	2.11	2.30
98050-0238	98054-0238	2.38	2.24	2.43
98050-0250	98054-0250	2.50	2.36	2.55
98050-0256	98054-0256	2.56	2.42	2.61
98050-0262	98054-0262	2.62	2.48	2.67
98050-0275	98054-0275	2.75	2.61	2.80
98050-0288	98054-0288	2.88	2.74	2.93
98050-0300	98054-0300	3.00	2.86	3.05
98050-0312	98054-0312	3.12	2.98	3.17
98050-0325	98054-0325	3.25	3.11	3.30
98050-0350	98054-0350	3.50	3.36	3.55
98050-0400	98054-0400	4.00	3.86	4.05
98050-0425	98054-0425	4.25	4.11	4.30
98050-0450	98054-0450	4.50	4.36	4.55
98050-0500	98054-0500	5.00	4.86	5.05
98050-0550	98054-0550	5.50	5.36	5.55
98050-0600	98054-0600	6.00	5.86	6.05
98050-0650	98054-0650	6.50	6.36	6.55
98050-0700	98054-0700	7.00	6.86	7.05
98050-0750	98054-0750	7.50	7.36	7.55
98050-0766	98054-0766	7.66	7.52	7.71
98050-0800	98054-0800	8.00	7.86	8.05
98050-0850	98054-0850	8.50	8.36	8.55

98052 Series

Standard Band Width = 0.75 in.

ZINC PLATED BARRELS

Specifications:

- 0.025 in. Thick 300 Series Stainless Band and Tongue
- 1/4-20 300 Series Stainless Steel SHCS
- Steel/Zinc Plate Barrel Hardware

Maximum Torque 75 in.-lbs.

98057 Series

Standard Band Width = 0.75 in.

STAINLESS STEEL BARRELS

Specifications:

- 0.025 in. Thick 300 Series Stainless Band and Tongue
- 1/4-20 300 Series Stainless Steel SHCS
- 300 Series Stainless Barrel Hardware

Maximum Torque 75 in.-lbs.

ENGLISH (inches)				
PART NUMBER	PART NUMBER	NOMINAL DIAMETER	MINIMUM DIAMETER	MAXIMUM DIAMETER
98052-0150	98057-0150	1.50	1.36	1.64
98052-0175	98057-0175	1.75	1.61	1.89
98052-0188	98057-0188	1.88	1.74	2.02
98052-0200	98057-0200	2.00	1.86	2.14
98052-0212	98057-0212	2.12	1.98	2.26
98052-0225	98057-0225	2.25	2.11	2.39
98052-0238	98057-0238	2.38	2.24	2.52
98052-0250	98057-0250	2.50	2.36	2.64
98052-0256	98057-0256	2.56	2.42	2.70
98052-0262	98057-0262	2.62	2.48	2.76
98052-0275	98057-0275	2.75	2.61	2.89
98052-0288	98057-0288	2.88	2.74	3.02
98052-0300	98057-0300	3.00	2.86	3.14
98052-0312	98057-0312	3.12	2.98	3.26
98052-0325	98057-0325	3.25	3.11	3.39
98052-0350	98057-0350	3.50	3.36	3.64
98052-0400	98057-0400	4.00	3.86	4.14
98052-0425	98057-0425	4.25	4.11	4.39
98052-0450	98057-0450	4.50	4.36	4.64
98052-0500	98057-0500	5.00	4.86	5.14
98052-0550	98057-0550	5.50	5.36	5.64
98052-0600	98057-0600	6.00	5.86	6.14
98052-0650	98057-0650	6.50	6.36	6.64
98052-0700	98057-0700	7.00	6.86	7.14
98052-0750	98057-0750	7.50	7.36	7.64
98052-0766	98057-0766	7.66	7.52	7.80
98052-0800	98057-0800	8.00	7.86	8.14
98052-0850	98057-0850	8.50	8.36	8.64

98071 Metric Series (No Welded Tongue)

Standard Band Width = 0.75 in.

STEEL, ZINC PLATED BARRELS

Specifications:

- 0.025 in. Thick 300 Series Stainless Band
- M6 X 1.0 Steel/Zinc Plate SHCS
- Steel/Zinc Plate Barrel Hardware

Maximum Torque 75 in.-lbs.

98072 Metric Series (Welded Tongue)

Standard Band Width = 0.75 in.

STEEL, ZINC PLATED BARRELS

Specifications:

- 0.025 in. Thick 300 Series Stainless Band and Tongue
- M6 X 1.0 Steel/Zinc Plate SHCS
- Steel/Zinc Plate Barrel Hardware

Maximum Torque 75 in.-lbs.

ENGLISH (inches)				
PART NUMBER	PART NUMBER	NOMINAL DIAMETER	MINIMUM DIAMETER	MAXIMUM DIAMETER
98071-0150	98072-0150	1.50	1.36	1.64
98071-0175	98072-0175	1.75	1.61	1.89
98071-0188	98072-0188	1.88	1.74	2.02
98071-0200	98072-0200	2.00	1.86	2.14
98071-0212	98072-0212	2.12	1.98	2.26
98071-0225	98072-0225	2.25	2.11	2.39
98071-0238	98072-0238	2.38	2.24	2.52
98071-0250	98072-0250	2.50	2.36	2.64
98071-0256	98072-0256	2.56	2.42	2.70
98071-0262	98072-0262	2.62	2.48	2.76
98071-0275	98072-0275	2.75	2.61	2.89
98071-0288	98072-0288	2.88	2.74	3.02
98071-0300	98072-0300	3.00	2.86	3.14
98071-0312	98072-0312	3.12	2.98	3.26
98071-0325	98072-0325	3.25	3.11	3.39
98071-0350	98072-0350	3.50	3.36	3.64
98071-0400	98072-0400	4.00	3.86	4.14
98071-0425	98072-0425	4.25	4.11	4.39
98071-0450	98072-0450	4.50	4.36	4.64
98071-0500	98072-0500	5.00	4.86	5.14
98071-0550	98072-0550	5.50	5.36	5.64
98071-0600	98072-0600	6.00	5.86	6.14
98071-0650	98072-0650	6.50	6.36	6.64
98071-0700	98072-0700	7.00	6.86	7.14
98071-0750	98072-0750	7.50	7.36	7.64
98071-0766	98072-0766	7.66	7.52	7.80
98071-0800	98072-0800	8.00	7.86	8.14
98071-0850	98072-0850	8.50	8.36	8.64

WORM GEAR CLAMPS

Zinc Plated & Stainless Steel Worm Screw

Standard and Custom

Clampco supplies Worm Gear Clamps to customers who prefer to one-stop shop. The Worm Gear Clamps are available in standard SAE sizes and materials. Consult the Worm Gear Clamp charts below for exact sizes and materials. Custom designs are also available. Contact Clampco with your special requests.



90037 Micro Series: Band Width = 0.312 in.

1/4 in. Hex Head Carbon Steel Zinc Plated Worm / 300 Series Stainless Steel Band and Housing / Maximum Torque = 20 in.-lbs.

90009 Standard Series: Band Width = 0.50 in.

5/16 in. Hex Head Carbon Steel Zinc Plated Worm / 300 Series Stainless Steel Band and Housing / Maximum Torque = 50 in.-lbs.

ZINC PLATED WORM SCREW

ENGLISH (inches)				
MICRO BAND NO.	STANDARD BAND NO.	SAE	MINIMUM DIAMETER	MAXIMUM DIAMETER
90037-0062	N/A	04	0.25	0.62
90037-0078	90009-0078	06	0.44	0.78
90037-0091	90009-0091	08	0.50	0.91
CALL	90009-0106	10	0.56	1.06
CALL	90009-0125	12	0.69	1.25
CALL	90009-0150	16	0.81	1.50
CALL	90009-0175	20	0.81	1.75
CALL	90009-0200	24	1.06	2.00
CALL	90009-0225	28	1.31	2.25
CALL	90009-0250	32	1.56	2.50
CALL	90009-0275	36	1.81	2.75
CALL	90009-0300	40	2.06	3.00
CALL	90009-0325	44	2.31	3.25
CALL	90009-0350	48	2.56	3.50
CALL	90009-0375	52	2.81	3.75
CALL	90009-0400	56	3.06	4.00
CALL	90009-0425	60	3.31	4.25
CALL	90009-0450	64	3.56	4.50
CALL	90009-0500	72	4.06	5.00
CALL	90009-0550	80	4.62	5.50
CALL	90009-0600	88	5.12	6.00
CALL	90009-0650	96	5.56	6.50
CALL	90009-0700	104	6.18	7.00

Call Clampco for larger sizes.

90038 Micro Series: Band Width = 0.312 in.

300 Series Stainless Steel 1/4 in. Hex Head Worm, Band and Housing / Maximum Torque = 20 in.-lbs.

90016 Standard Series: Band Width = 0.50 in.

300 Series Stainless Steel 5/16 in. Hex Head Worm, Band and Housing / Maximum Torque = 50 in.-lbs.

STAINLESS STEEL WORM SCREW

ENGLISH (inches)				
MICRO BAND NO.	STANDARD BAND NO.	SAE	MINIMUM DIAMETER	MAXIMUM DIAMETER
90038-0062	N/A	04	0.25	0.62
90038-0078	90016-0078	06	0.44	0.78
90038-0091	90016-0091	08	0.50	0.91
CALL	90016-0106	10	0.56	1.06
CALL	90016-0125	12	0.69	1.25
CALL	90016-0150	16	0.81	1.50
CALL	90016-0175	20	0.81	1.75
CALL	90016-0200	24	1.06	2.00
CALL	90016-0225	28	1.31	2.25
CALL	90016-0250	32	1.56	2.50
CALL	90016-0275	36	1.81	2.75
CALL	90016-0300	40	2.06	3.00
CALL	90016-0325	44	2.31	3.25
CALL	90016-0350	48	2.56	3.50
CALL	90016-0375	52	2.81	3.75
CALL	90016-0400	56	3.06	4.00
CALL	90016-0425	60	3.31	4.25
CALL	90016-0450	64	3.56	4.50
CALL	90016-0500	72	4.06	5.00
CALL	90016-0550	80	4.62	5.50
CALL	90016-0600	88	5.12	6.00
CALL	90016-0650	96	5.56	6.50
CALL	90016-0700	104	6.18	7.00

Call Clampco for larger sizes. *Clampco reserves the right to substitute 200 Series Stainless Steel for 300 Series Stainless Steel for band/housing

**CLAMP
CO
CUSTOM**

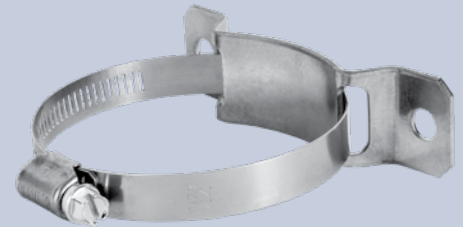

Custom Order

Clampco can accommodate special requests for notched band designs. Limited or extended slot options are available for non-standard adjustment ranges. Alternate materials are also an option.

We Customize. Call Today.



Custom Order

We can also manufacture V-Band Couplings with Worm Gear Clamps as the outer bands. This style is commonly used on dairy processing equipment, irrigation systems, and agricultural equipment.

We Customize. Call Today.

V-BAND CLAMPS/COUPLINGS

Standard/Stock Items

In Stock and Ready to Deliver!

Clampco stocks several standard V-Band Clamps/Couplings. These parts are the most popular sizes and are frequently installed on diesel engines, turbochargers, and heavy-duty exhaust systems.

All of our standard V-Band Clamps/Couplings have 300 series stainless steel bands and retainers and come with a standard T-Bolt Latch. See the following catalog pages on V-Band Clamps/Couplings for more detailed product specifications and dimensions.



V-BAND CLAMPS/COUPLINGS

ENGLISH (inches)				
DESCRIPTION CODE	PART NUMBER	FLANGE APEX	FLANGE O.D.	
Ⓢ V0135100M-0320-S2	995CS-0320	0.296	3.106	
Ⓢ V0138108N-0382-S2	99800-0382	0.255	3.695	
Ⓢ V0135200M-0388-S2	99502-0388	0.443	3.755	
Ⓢ V0135100M-0410-S2	99506-0410	0.296	4.006	
Ⓢ V0135200M-0425-S2	99502-0425	0.443	4.125	
Ⓢ V0138108N-0450-S2	99800-0450	0.255	4.375	
Ⓢ V0135200M-0462-S2	99502-0462	0.443	4.495	
Ⓢ V0135200M-0475-S2	99502-0475	0.443	4.625	
Ⓢ V0138108N-0481-S2	99800-0481	0.255	4.685	
Ⓢ V0135100M-0525-S2	99506-0525	0.296	5.156	
Ⓢ V0135200M-0588-S2	99502-0588	0.443	5.755	
Ⓢ V0139115M-0592-S2	99915-0592	0.340	5.795	

Ⓢ = Stock Items



Now stocking V-Band Clamps/Couplings sizes for quick shipment!



V-BAND CLAMPS/COUPLINGS

Made-to-Order

Clampco V-Band Couplings, also known as V-Band Clamps or V-Clamps, join flanges with V-shaped Retainer profiles. A V-Band Coupling operates by exerting a wedging load, which squeezes the flanges together. The V-Band Couplings can be designed to work with or without gaskets and O-rings. The material gauge, latch style and number of retainer segments all vary depending on the requirements for each application.



V-Band Couplings eliminate the need for cumbersome bolted flange designs and costly welded flange designs. Because V-Band Couplings can be easily assembled and disassembled, they are often used on equipment that requires frequent service or maintenance. Typical V-Band applications include Turbochargers, Diesel After-treatment and Exhaust Systems, Pumps, Filters and Fluid/Bulk Solids Processing Equipment.

How to Determine your V-Band Clamp/Coupling Description Code

Clampco's description code contains 7 segments, each representing a different part of the clamp. Below is a sample description code:

V01-3-52-00-N-0588-S2

It's easy to create your made-to-order V-Band Clamp/Coupling description code, just follow these 7 easy steps:

1. Determine Latch & Band or Strap Style Code

V01-3-52-00-N-0588-S2

2. Determine Number of Retainer Segments

V01-**3**-52-00-N-0588-S2

3. Determine Retainer Series Code

V01-3-**52**-00-N-0588-S2

4. Determine Product Design Code

V01-3-52-**00**-N-0588-S2

5. Determine Bolt Code

V01-3-52-00-**N**-0588-S2

6. Determine Retainer Inside Diameter Code

V01-3-52-00-N-**0588**-S2

7. Determine Nut, Knob, or T-Handle Code

V01-3-52-00-N-0588-**S2**

CLAMPKO LATCH STYLES



T-BOLT LATCH

The Clampco T-Bolt Latch is used for permanent or semi-permanent applications and/or safety on pressurized systems. The T-Bolt Latch is our most economical latch.



QUICK RELEASE LATCH

The Clampco Quick Release Latch is used for ease of disassembly and is required where the ability to replace bolts is desired.



SADDLE QUICK RELEASE LATCH

The Saddle Quick Release Latch is also used for ease of disassembly and where the ability to replace bolts is desired. It is not recommended for diameters larger than 10 in. due to trunnion/band interference.



LIGHT-DUTY OVER CENTER LATCH

The Light-Duty Over Center Latch is used on applications that require frequent assembly or disassembly. No tools are required for opening and closing the clamp after initial installation. This latch style is ideal for light-duty applications on small diameters and requires a 3/16 in. diameter T-Bolt. Uncaptured T-Bolt head standard. Captured T-Bolt head offered as an option.

(Note: Not for use on pressurized V-Band applications.)



MEDIUM-DUTY OVER CENTER LATCH

The Medium-Duty Over Center Latch is well suited for heavier applications and on larger diameters. No tools are required for opening and closing the clamp after initial installation. It is available with either a 1/4 in. or 5/16 in. diameter T-Bolt. Uncaptured T-Bolt head standard. Captured T-Bolt head offered as an option.

(Note: Minimum Band Width - 7/8 in.)

(Note: Not for use on pressurized V-Band applications.)



HEAVY-DUTY OVER CENTER LATCH

The Heavy-Duty Over Center Latch is well suited for heavy-duty applications and large diameters. It is available with a 3/8 in. diameter T-Bolt.

(Note: Minimum Band Width - 1-1/4 in.)

(Note: Not for use on pressurized V-Band applications.)

SPECIFICATIONS

1. DETERMINE LATCH & BAND OR STRAP STYLE

V01-3-52-00-N-0588-S2 (Sample Description Code)

Clampco offers several latch styles and latch combinations for your Custom V-Band application. Choose the code that corresponds with the best design for your application.

FULL BANDS: SINGLE LATCH

Full Band Styles are recommended where greater strength is required.

CODE	LATCH STYLE
V01	T-Bolt
V02	Quick Release
V03	Saddle Quick Release
V07	Light-Duty Over Center
V09	Medium-Duty Over Center

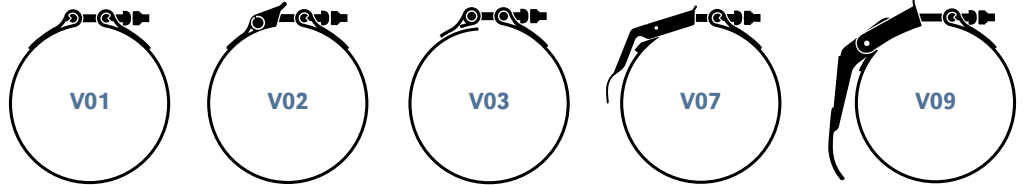

FULL BANDS: MULTIPLE LATCHES

Full Band Styles are recommended where greater strength is required.

CODE	LATCH STYLE
V11	Two T-Bolts
V21	Quick Release and T-Bolt
V31	Saddle Quick Release and T-Bolt
V71	Light-Duty Over Center and T-Bolt
V91	Medium-Duty Over Center and T-Bolt

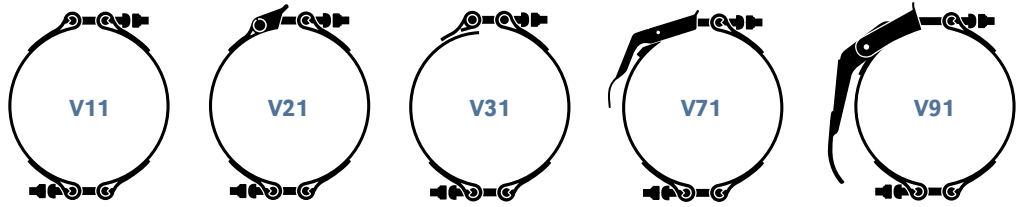

STRAP BANDS: SINGLE LATCH

Strap Band Styles are more economical for diameters 8-10 in. [203-254 mm] and larger.

CODE	LATCH STYLE
V01T	T-Bolt
V02T	Quick Release
V03T	Saddle Quick Release
V07T	Light-Duty Over Center
V09T	Medium-Duty Over Center

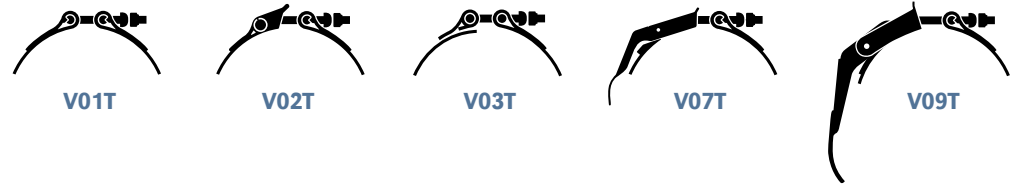

STRAP BANDS: MULTIPLE LATCHES

Strap Band Styles are more economical for diameters 8-10 in. [203-254 mm] and larger.

CODE	LATCH STYLE
V11T	Two T-Bolts
V21T	Quick Release and T-Bolt
V31T	Saddle Quick Release and T-Bolt
V71T	Light-Duty Over Center and T-Bolt
V91T	Medium-Duty Over Center and T-Bolt

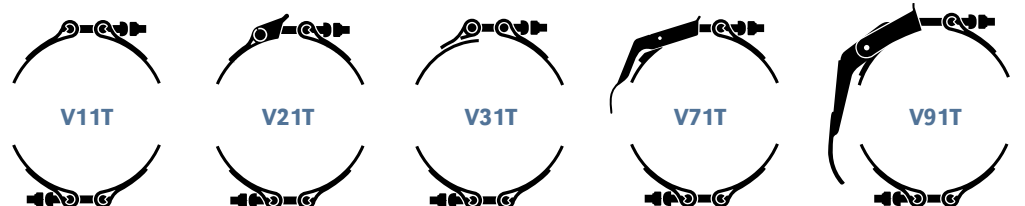

2. DETERMINE NUMBER OF RETAINER SEGMENTS

V01-3-52-00-N-0588-S2 (Sample Description Code)

Clampco offers one, two, three and four-segment V-Band Couplings.

(Note: Over Center Latch options not for use on pressurized V-Band applications.)

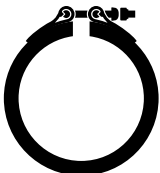
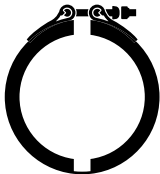
NUMBER OF SEGMENTS	LATCH DESCRIPTION
1	 <p>One-segment retainers are available for large couplings (approximately 12 in. [304.8 mm] and larger). One-segment retainers are difficult to install due to their inherent stiffness. Therefore, they should be used on permanent applications. One-segment retainers can only be used with latch & band styles V01, V02, V03, V07, V09, V01T, V02T, V03T, V07T, and V09T</p>
2	 <p>Two-segment retainers are also generally used for V-Band Couplings 8-10 in. [203-254 mm] and larger. However, they provide increased installation and removal flexibility. Two-segment retainers are primarily recommended for double latch clamps but can be used with single latch clamps. Please note: Two segment retainers CANNOT be used with latch & band styles V01T, V02T, V03T, V07T, and V09T</p>

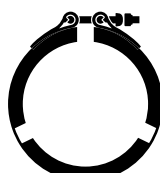
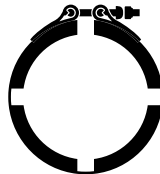
NUMBER OF SEGMENTS	LATCH DESCRIPTION
3	 <p>Three-segment retainers are used for all coupling diameters, especially those 8-10 in. [203-254 mm] and smaller. Three-segment retainers provide even greater ease of assembly and disassembly and offer the best balance between functionality and economy. Three-segment retainers can only be used with latch & band styles V01, V02, V03, V07 and V09.</p>
4	 <p>Four-segment retainers are only recommended for exceptionally large couplings where two or three segments are not adequate. Four-segment retainers can only be used with latch & band styles V01, V02, V03, V07, V09, V11, V21, V31, V71 and V91.</p>

V-BAND CLAMPS/COUPLINGS

Made-to-Order

3. DETERMINE RETAINER SERIES CODE

V01-3-**52**-00-N-0588-S2 (Sample Description Code)

Clampco is currently tooled for over 20 standard profiles. These retainer profiles provide an optimized fit with the most common industrial flange geometries. To arrive at the proper retainer series for your application, please consider the following factors: the design and dimensions of the mating flanges; operating pressure and temperature; whether or not gaskets or O-rings will be used; and what the system will carry (fluid, dry bulk solids, air, etc.).

Have an application requiring a custom retainer profile? Simply provide your joint geometry and Clampco will design a custom retainer profile to meet your needs.



RETAINER THICKNESS OF 0.031 in. [.787 mm]

ENGLISH (inches)			METRIC (millimeters)		
COUPLING DIAMETER	PRESSURE IN PSI		COUPLING DIAMETER	PRESSURE IN MPa	
	FULL BAND	STRAP BAND		FULL BAND	STRAP BAND
2	500	380	51	3.45	2.62
4	250	180	102	1.72	1.24
6	140	95	152	0.96	0.65
8	80	65	203	0.55	0.45
10	60	50	254	0.41	0.34
12	45	38	305	0.31	0.26
14	38	32	355	0.26	0.22
16	32	28	406	0.22	0.19
18	28	25	457	0.19	0.17
20	25	23	508	0.17	0.16

WARNING: The pressure ratings shown are the maximum pressures that will not cause yielding of any component. The ratings are for V-Band Clamps/Couplings with the following: 301 annealed retainers with 40 degree included angles; 301/302/304 1/4 hard or 1/2 hard bands; and operating at ambient temperatures of 70 degrees F. See the Materials and Temperatures Chart on page 36 to calculate pressure ratings for different materials and temperatures. Do not use pressure ratings for over center latch styles or for any other latch styles that are tightened by hand. Vessel pressure must be released before coupling is opened.

RETAINER THICKNESS OF 0.040 in. [1.02 mm]

ENGLISH (inches)			METRIC (millimeters)		
COUPLING DIAMETER	PRESSURE IN PSI		COUPLING DIAMETER	PRESSURE IN MPa	
	FULL BAND	STRAP BAND		FULL BAND	STRAP BAND
2	1500	620	51	10.34	4.27
4	450	300	102	3.10	2.07
6	240	180	152	1.65	1.24
8	150	120	203	1.03	0.83
10	110	80	254	0.76	0.55
12	80	60	305	0.55	0.41
14	65	50	355	0.45	0.34
16	55	40	406	0.38	0.28
18	50	35	457	0.34	0.24
20	45	30	508	0.31	0.21

RETAINER THICKNESS OF 0.070 in. [1.78 mm]

ENGLISH (inches)			METRIC (millimeters)		
COUPLING DIAMETER	PRESSURE IN PSI		COUPLING DIAMETER	PRESSURE IN MPa	
	FULL BAND	STRAP BAND		FULL BAND	STRAP BAND
2	3150	1250	51	21.72	8.62
4	1100	650	102	7.58	4.48
6	600	400	152	4.14	2.76
8	350	280	203	2.41	1.93
10	250	210	254	1.72	1.45
12	200	160	305	1.38	1.10
14	170	120	355	1.17	0.83
16	150	100	406	1.03	0.69
18	120	90	457	0.83	0.62
20	100	70	508	0.69	0.48

RETAINER THICKNESS OF 0.050 in. [1.27 mm]

ENGLISH (inches)			METRIC (millimeters)		
COUPLING DIAMETER	PRESSURE IN PSI		COUPLING DIAMETER	PRESSURE IN MPa	
	FULL BAND	STRAP BAND		FULL BAND	STRAP BAND
2	2000	700	51	13.79	4.83
4	650	320	102	4.48	2.21
6	350	200	152	2.41	1.38
8	210	140	203	1.45	0.96
10	150	100	254	1.03	0.69
12	120	80	305	0.83	0.55
14	90	65	355	0.62	0.45
16	80	60	406	0.55	0.55
18	70	52	457	0.48	0.36
20	65	46	508	0.45	0.32

RETAINER THICKNESS OF 0.080 in. [2.03 mm]

ENGLISH (inches)			METRIC (millimeters)		
COUPLING DIAMETER	PRESSURE IN PSI		COUPLING DIAMETER	PRESSURE IN MPa	
	FULL BAND	STRAP BAND		FULL BAND	STRAP BAND
2	4000	1600	51	27.58	11.03
4	1500	780	102	10.34	5.38
6	750	500	152	5.17	3.45
8	500	340	203	3.45	2.34
10	360	260	254	2.48	1.79
12	280	200	305	1.93	1.38
14	240	160	355	1.45	1.10
16	180	140	406	1.24	0.96
18	150	120	457	1.03	0.83
20	130	100	508	0.90	0.69

RETAINER THICKNESS OF 0.062 in. [1.57 mm]

ENGLISH (inches)			METRIC (millimeters)		
COUPLING DIAMETER	PRESSURE IN PSI		COUPLING DIAMETER	PRESSURE IN MPa	
	FULL BAND	STRAP BAND		FULL BAND	STRAP BAND
2	2500	1000	51	17.24	6.89
4	800	550	102	5.52	3.79
6	480	350	152	3.31	2.41
8	300	250	203	2.07	1.72
10	240	180	254	1.65	1.24
12	180	150	305	1.24	1.03
14	160	120	355	1.10	0.83
16	130	90	406	0.90	0.62
18	110	78	457	0.76	0.54
20	100	68	508	0.69	0.47

RETAINER THICKNESS OF 0.090 in. [2.29 mm]

ENGLISH (inches)			METRIC (millimeters)		
COUPLING DIAMETER	PRESSURE IN PSI		COUPLING DIAMETER	PRESSURE IN MPa	
	FULL BAND	STRAP BAND		FULL BAND	STRAP BAND
2	5500	3800	51	37.92	26.20
4	2000	1500	102	13.79	10.34
6	1200	800	152	8.27	5.52
8	780	550	203	5.38	3.79
10	580	400	254	3.99	2.76
12	440	310	305	3.03	2.14
14	350	260	355	2.41	1.79
16	290	210	406	1.99	1.45
18	250	180	457	1.72	1.24
20	200	150	508	1.38	1.03

SPECIFICATIONS

RETAINER THICKNESS OF 0.031 in. [.787 mm]

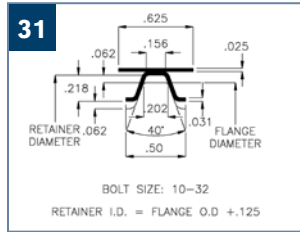

RETAINER THICKNESS OF 0.040 in. [1.02 mm]

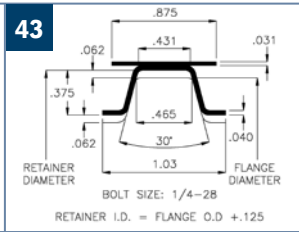
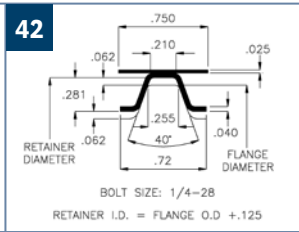
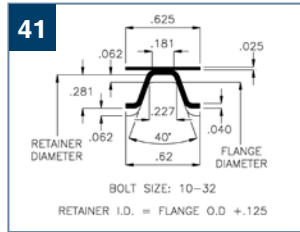

RETAINER THICKNESS OF 0.050 in. [1.27 mm]

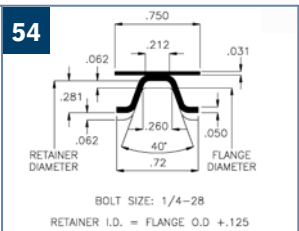
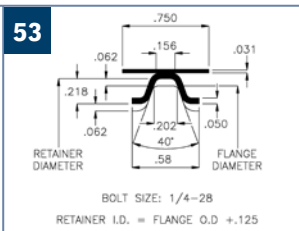
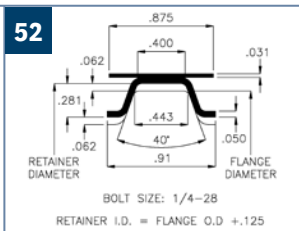
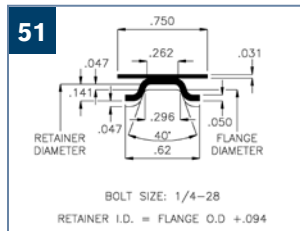

RETAINER THICKNESS OF 0.062 in. [1.57 mm]

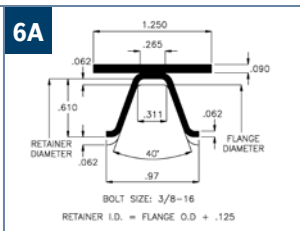
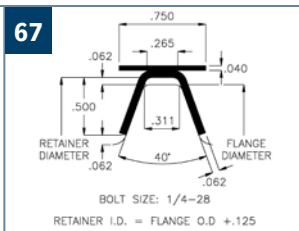
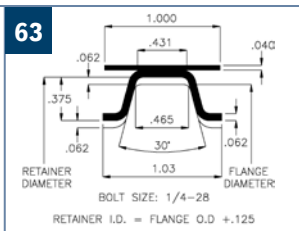
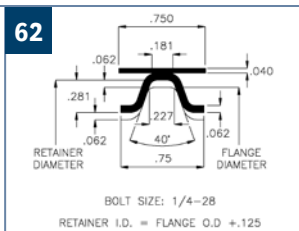
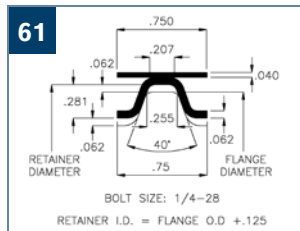

RETAINER THICKNESS OF 0.070 in. [1.78 mm]

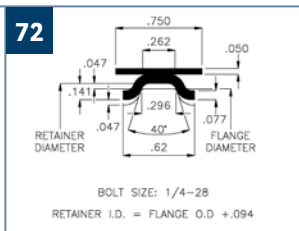
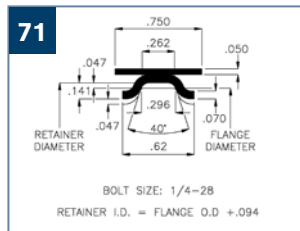

RETAINER THICKNESS OF 0.080 in. [2.03 mm]

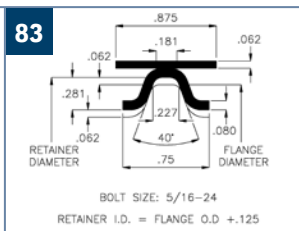
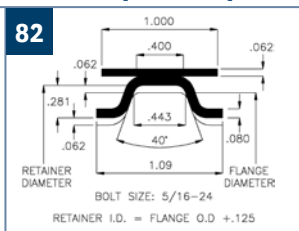
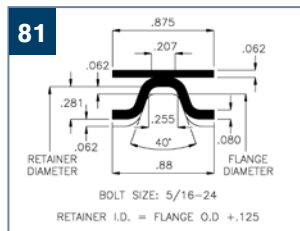

RETAINER THICKNESS OF 0.090 in. [2.29 mm]

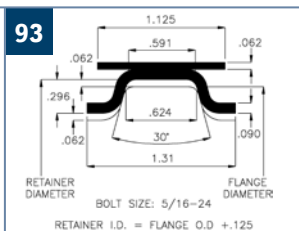
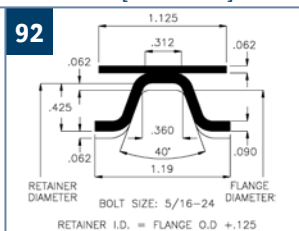
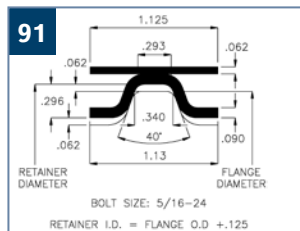

DESIGN CONSIDERATIONS

Application Loads

See the V-Band Clamp/Coupling load formulas on page 36 for applications involving bending moments and/or axial loads in addition to pressure loads.

Safety Factor

Choose the thinnest material for the application that still meets the performance requirements, including **your appropriate safety factor** and material and temperature corrections.

Retainer Series

Retainer series are available in 301/302/304 annealed stainless steel. Other materials are available upon request.

To use a standard retainer series the flange apex width (including compressed flat gasket or O-ring) must be as shown. Other flange apex widths require special retainer series not shown.

Select a retainer series with enough opening (at the bottom of the retainer) so that the retainers can grab (or catch) the free state flanges sufficiently to prepare the joint for tightening.

Retainer series profile dimensions are in inches; 1 in. = 25.4 mm

V-BAND CLAMPS/COUPLINGS

Made-to-Order

4. DETERMINE PRODUCT DESIGN CODE

V01-3-52-**00**-N-0588-S2 (Sample Description Code)

The standard design code is "00" for all V-Band Couplings. A unique design code is assigned to custom parts. Custom parts include variations such as different band and retainer materials, non-standard hardware, special retainer profiles, custom markings, and more. Parts with different over center latch designs, along with their corresponding safety features, are also custom items and will receive a special design code. (See pages 28–29 for more information regarding custom options.)

Clampco will assign the design code that represents your custom part upon receipt of an order.

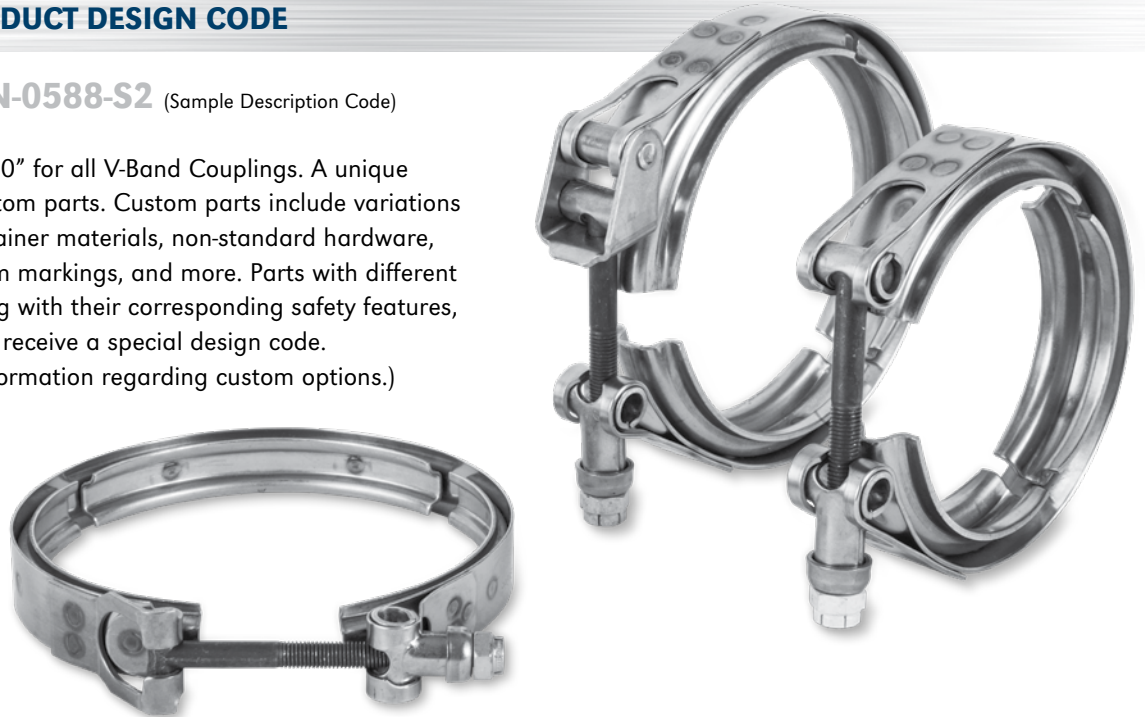

5. DETERMINE BOLT CODE

V01-3-52-00-**N**-0588-S2 (Sample Description Code)

Clampco offers the following bolts as standard options. Other bolt materials and thread sizes are available upon request. Some bolts may be bent for small diameter applications.

CODE	BOLT DESCRIPTION	THREAD SIZE
C	4037 Alloy Heat Treated to 125,000 to 145,000 psi, Zinc Plated	10-32 1/4-28 M6 X 1 5/16-24 3/8-16 1/2-13
N	18-8 Stainless Steel (302 or 305)	10-32 1/4-20 1/4-28 5/16-18 5/16-24 3/8-16
M	431, 420 or 410 Stainless Steel Heat Treated to 140,000 to 160,000 psi	10-32 1/4-28 M6 X 1 5/16-24 M8 X 1.25
A	A286 Stainless Steel, 130,000 psi minimum	10-32 1/4-28
W	316 Stainless Steel	1/4-28 M6 X 1 M8 X 1.25

*Inquire about additional materials and coatings

Bolt Performance and Torque Chart

THREAD SIZE	BOLT MATERIAL	MAXIMUM	
		RECOMMENDED TORQUE IN. - LBS.	ULTIMATE TENSILE STRENGTH LBS.
10-32	300 Series Stainless Steel	50	1815
10-32	Type 410, 420 or 431 Stainless Steel	66	2390
10-32	Type A286 Stainless Steel	65	2390
10-32	Plated Alloy Steel	65	2390
1/4-20	300 Series Stainless Steel	75	3322
1/4-28	300 Series Stainless Steel	75	3322
M6 X 1	300 Series Stainless Steel	75	3322
1/4-28	Type 410, 420 or 431 Stainless Steel	90	4370
M6 X 1	Type 410, 420 or 431 Stainless Steel	90	4370
1/4-28	Type A286 Stainless Steel	90	4370
1/4-28	Plated Alloy Steel	90	4370
M6 X 1	Plated Alloy Steel	90	4370
5/16-18	300 Series Stainless Steel	180	5320
5/16-24	300 Series Stainless Steel	180	5320
M8 X 1.25	300 Series Stainless Steel	180	5320
5/16-24	Type 410, 420 or 431 Stainless Steel	240	7000
M8 X 1.25	Type 410, 420 or 431 Stainless Steel	240	7000
5/16-24	Type A286 Stainless Steel	240	7000
5/16-24	Plated Alloy Steel	240	7000
3/8-16	300 Series Stainless Steel	390	7100
3/8-16	Plated Alloy Steel	480	9350
1/2-13	Plated Alloy Steel	550	17200

300 series stainless steel bolt strength based on 95,000 psi minimum tensile strength. Type 410-431 stainless steel bolt strength based on 125,000 psi minimum tensile strength. Type A286 stainless steel bolt strength based on 125,000 psi minimum tensile strength. Plated alloy steel bolt strength based on 125,000 psi minimum tensile strength. Torque coupling or band to a level where joints are properly closed. Maximum torque levels are not required for proper joint function.

SPECIFICATIONS

6. DETERMINE RETAINER INSIDE DIAMETER CODE

V01-3-52-00-N-**0588**-S2 (Sample Description Code)

The retainer inside diameter (I.D.) must be specified in .01 in. increments. It is determined by adding the flange outside diameter (O.D.) plus the recommended air gap for the retainer series. The last 2 digits of the code are represented as a two place decimal number without the decimal point.

For Example:

You have a flange with an O.D. of 5.750 in. designed for use with a 52 series retainer. See 52 series chart to determine what should be added to flange O.D. to get retainer I.D.

1. ADD FLANGE O.D. AND RECOMMENDED AIR GAP FROM CHART TO GET RETAINER SERIES I.D.
 5.750 in. + 0.125 in. = 5.875 in.

2. ROUND TO NEAREST TWO PLACE DECIMAL: 5.88

3. DROP THE DECIMAL POINT TO ARRIVE AT YOUR CODE: 588

When starting with a metric unit, convert millimeters to inches rounded to two decimal places, and then drop the decimal point.

For Example:

60 mm = (60 mm/25.4) = 2.36 in. = 236







Remember...The V-Band I.D. is always larger than the flange O.D.



7. DETERMINE NUT, KNOB, OR T-HANDLE CODE











V01-3-52-00-N-0588-**S2** (Sample Description Code)

Clampco provides the following Nuts, Knobs and T-Handles as standard options. Choose the Nut, Knob or T-Handle that is best suited to your application, or contact our sales department with your special request.

CODE	KNOB AND T-HANDLE DESCRIPTION	THREAD SIZE
K	 Knob for hand tightening, plastic with Brass insert, 1 in. long	10-32 1/4-28
K1	 Knob for hand tightening, plastic with Brass insert, 1.75 in. long	1/4-20 1/4-28
T	 T-Handle for hand tightening, Steel/Zinc Plated, 3 in. long	10-32 1/4-28 5/16-24
T2	 T-Handle for hand tightening, Steel/Zinc Plated, 2.125 in. long	1/4-28
T7	 T-Handle for hand tightening, 400 series Stainless Steel, 3 in. long	1/4-28 5/16-24
T9	 T-Handle for hand tightening, 300 series Stainless Steel, 3 in. long	5/16-24
T14	 T-Handle for hand tightening, 300 series Stainless Steel, 3 in. long	1/4-28



NOTE:
 See pages 30 and 31 for additional Knob and T-Handle information.

CODE	NUT DESCRIPTION	THREAD SIZE	TEMP RATING	SELF-LOCKING
S	 Steel, self-locking, nylon insert, Zinc Plated	10-32 1/4-28 5/16-24 M6 X 1	250° F	Yes
S1	 All metal, Steel, self-locking, collar or short beam design, Silver Plated	10-32 1/4-28 5/16-24 3/8-16	550° F	Yes
S2	 All metal, 18-8 Stainless Steel*, self-locking, collar or short beam design, Silver Plated	10-32 1/4-28 5/16-24 3/8-16	800° F	Yes
S3	 All metal, 347 Stainless Steel*, self-locking, collar or short beam design, Silver Plated	10-32 1/4-28 5/16-24	1200° F	Yes
S4	 18-8 Stainless Steel, self-locking, nylon insert, Silver Plated	10-32 1/4-28 5/16-24 3/8-16	250° F	Yes
S6	 All metal, 347 Stainless Steel, self-locking, long beam design, Silver Plated	10-32 1/4-28	1200° F	Yes
S14	 316 Stainless Steel, self-locking, nylon insert, Silver Plated	1/4-28 5/16-24 M6 X 1 M8 X 1.25	250° F	Yes
S22	 All metal, 300 series Stainless Steel, self-locking, Silver Plated, Emuge Style Thread design	M8 X 1.25	800° F	Yes
H	 Stainless Steel Hex Nut, Silver Plated	10-32 1/4-28 5/16-24 3/8-16 M6 X 1 M8 X 1.25	800° F	No
H6	 Steel Hex Nut, Zinc Plated	10-32 1/4-28 5/16-24 3/8-16	-	No
H8	 Brass Hex Nut	10-32 1/4-28 5/16-24 3/8-16	-	No

*We reserve the right to substitute with A286 stainless steel and/or other equivalent locknuts unless otherwise specified.

FLANGES

Machined Flanges (No Gasket)



Optimized Joint Solution

Machined flanges work in tandem with our stock and custom manufactured V-Band Couplings to provide a sealed joint. Dimensional data shown will provide valuable reference information that directly matches Standard Clampco V-Retainer Series Geometry found on page 21, thus avoiding tooling cost and reducing lead time. Machined Flange geometry can be modified to accommodate flat gaskets or grooves for O-ring seals, depending on your application. Alternate material options are also available.

See page 35 for additional information on how to determine the proper dimensions or your V-Band Coupling application.

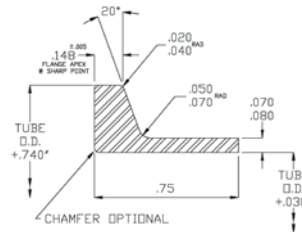

F1021 SERIES

303, 304, or 305 Stainless Steel
For use with Clampco Retainer Series 51 and 71

ENGLISH (inches)			
PART NUMBER	TUBE SIZE OUTSIDE DIAMETER	FLANGE INSIDE DIAMETER	FLANGE OUTSIDE DIAMETER
F1021M0150	1.50	1.53	2.24
F1021M0175	1.75	1.78	2.49
F1021M0200	2.00	2.03	2.74
F1021M0225	2.25	2.28	2.99
F1021M0250	2.50	2.53	3.24
F1021M0275	2.75	2.78	3.49
F1021M0300	3.00	3.03	3.74
F1021M0325	3.25	3.28	3.99
F1021M0350	3.50	3.53	4.24
F1021M0375	3.75	3.78	4.49
F1021M0400	4.00	4.03	4.74
F1021M0450	4.50	4.53	5.24
F1021M0500	5.00	5.03	5.74
F1021M0550	5.50	5.53	6.24
F1021M0600	6.00	6.03	6.74

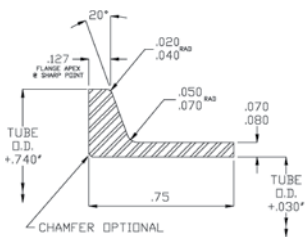

F1019 SERIES

303, 304, or 305 Stainless Steel
For use with Clampco Retainer Series 42, 54, 61, and 81

ENGLISH (inches)			
PART NUMBER	TUBE SIZE OUTSIDE DIAMETER	FLANGE INSIDE DIAMETER	FLANGE OUTSIDE DIAMETER
F1019M0150	1.50	1.53	2.24
F1019M0175	1.75	1.78	2.49
F1019M0200	2.00	2.03	2.74
F1019M0225	2.25	2.28	2.99
F1019M0250	2.50	2.53	3.24
F1019M0275	2.75	2.78	3.49
F1019M0300	3.00	3.03	3.74
F1019M0325	3.25	3.28	3.99
F1019M0350	3.50	3.53	4.24
F1019M0375	3.75	3.78	4.49
F1019M0400	4.00	4.03	4.74
F1019M0450	4.50	4.53	5.24
F1019M0500	5.00	5.03	5.74
F1019M0550	5.50	5.53	6.24
F1019M0600	6.00	6.03	6.74

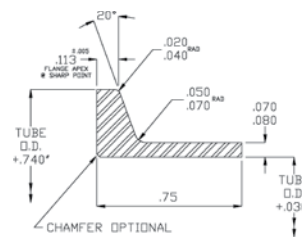

F1022 SERIES

303, 304, or 305 Stainless Steel
For use with Clampco Retainer Series 41, 62, and 83

ENGLISH (inches)			
PART NUMBER	TUBE SIZE OUTSIDE DIAMETER	FLANGE INSIDE DIAMETER	FLANGE OUTSIDE DIAMETER
F1022M0150	1.50	1.53	2.24
F1022M0175	1.75	1.78	2.49
F1022M0200	2.00	2.03	2.74
F1022M0225	2.25	2.28	2.99
F1022M0250	2.50	2.53	3.24
F1022M0275	2.75	2.78	3.49
F1022M0300	3.00	3.03	3.74
F1022M0325	3.25	3.28	3.99
F1022M0350	3.50	3.53	4.24
F1022M0375	3.75	3.78	4.49
F1022M0400	4.00	4.03	4.74
F1022M0450	4.50	4.53	5.24
F1022M0500	5.00	5.03	5.74
F1022M0550	5.50	5.53	6.24
F1022M0600	6.00	6.03	6.74

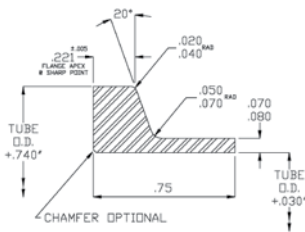

F1020 SERIES

303, 304, or 305 Stainless Steel
For use with Clampco Retainer Series 52 and 82

ENGLISH (inches)			
PART NUMBER	TUBE SIZE OUTSIDE DIAMETER	FLANGE INSIDE DIAMETER	FLANGE OUTSIDE DIAMETER
F1020M0150	1.50	1.53	2.24
F1020M0175	1.75	1.78	2.49
F1020M0200	2.00	2.03	2.74
F1020M0225	2.25	2.28	2.99
F1020M0250	2.50	2.53	3.24
F1020M0275	2.75	2.78	3.49
F1020M0300	3.00	3.03	3.74
F1020M0325	3.25	3.28	3.99
F1020M0350	3.50	3.53	4.24
F1020M0375	3.75	3.78	4.49
F1020M0400	4.00	4.03	4.74
F1020M0450	4.50	4.53	5.24
F1020M0500	5.00	5.03	5.74
F1020M0550	5.50	5.53	6.24
F1020M0600	6.00	6.03	6.74

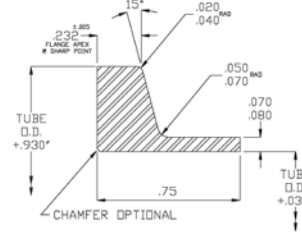

F1023 SERIES

303, 304, or 305 Stainless Steel
For use with Clampco Retainer Series 43 and 63

ENGLISH (inches)			
PART NUMBER	TUBE SIZE OUTSIDE DIAMETER	FLANGE INSIDE DIAMETER	FLANGE OUTSIDE DIAMETER
F1023M0150	1.50	1.53	2.43
F1023M0175	1.75	1.78	2.68
F1023M0200	2.00	2.03	2.93
F1023M0225	2.25	2.28	3.18
F1023M0250	2.50	2.53	3.43
F1023M0275	2.75	2.78	3.68
F1023M0300	3.00	3.03	3.93
F1023M0325	3.25	3.28	4.18
F1023M0350	3.50	3.53	4.43
F1023M0375	3.75	3.78	4.68
F1023M0400	4.00	4.03	4.93
F1023M0450	4.50	4.53	5.43
F1023M0500	5.00	5.03	5.93
F1023M0550	5.50	5.53	6.43
F1023M0600	6.00	6.03	6.93

FLANGES

Formed Sheet Metal Flanges

Lightweight Joint Solution

Formed Sheet Metal Flanges can also be coupled with Clampco V-Band Clamps to provide a lightweight, gasket-less option where low leak rate is allowable. As with the Machined Flanges, Clampco can align our customers with proven and reliable domestic partners that can manufacture these Formed Flanges to your specific dimensional and material requirements. From Industrial Ducting to Performance Racing, these Formed Flanges will offer a lightweight and low cost solution. For ease of installation, we recommend our quick release option as shown in the photo below.

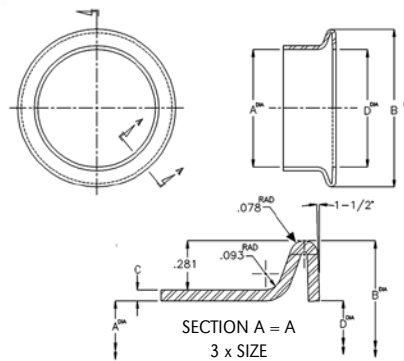

Thickness = 0.062 in. F1038S SERIES

301, 302, or 304 Stainless Steel
For use with Clampco Retainer Series 42, 54, 61, and 81

ENGLISH (inches)						
PART NUMBER	TUBE SIZE OUTSIDE DIAMETER	(A) FLANGE INSIDE DIAMETER	(B) FLANGE DIAMETER	(C) MINIMUM THICKNESS	(D) OPENING DIAMETER	COUPLING DIAMETER
F1038S150	1.50	1.510	2.196	0.062	1.590	2.32
F1038S175	1.75	1.760	2.446	0.062	1.840	2.57
F1038S200	2.00	2.010	2.696	0.062	2.090	2.82
F1038S225	2.25	2.260	2.946	0.062	2.340	3.07
F1038S250	2.50	2.510	3.196	0.062	2.590	3.32
F1038S275	2.75	2.760	3.446	0.062	2.840	3.57
F1038S300	3.00	3.010	3.696	0.062	3.090	3.82
F1038S325	3.25	3.260	3.946	0.062	3.340	4.07
F1038S350	3.50	3.510	4.196	0.062	3.590	4.32
F1038S375	3.75	3.760	4.446	0.062	3.840	4.57
F1038S400	4.00	4.010	4.696	0.062	4.090	4.82
F1038S450	4.50	4.510	5.196	0.062	4.590	5.32
F1038S500	5.00	5.010	5.696	0.062	5.090	5.82
F1038S550	5.50	5.510	6.196	0.062	5.590	6.32
F1038S600	6.00	6.010	6.696	0.062	6.090	6.82

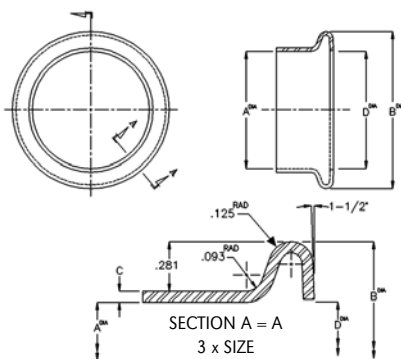

Thickness = 0.062 in. F1034S SERIES

301, 302, or 304 Stainless Steel
For use with Clampco Retainer Series 52 and 82

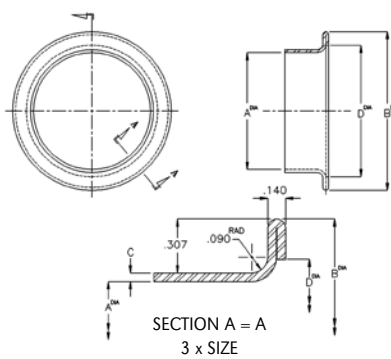

Thickness = 0.050 in. F1039S SERIES

301, 302, or 304 Stainless Steel
For use with Clampco Retainer Series 42, 54, 61, and 81

ENGLISH (inches)						
PART NUMBER	TUBE SIZE OUTSIDE DIAMETER	(A) FLANGE INSIDE DIAMETER	(B) FLANGE DIAMETER	(C) MINIMUM THICKNESS	(D) OPENING DIAMETER	COUPLING DIAMETER
F1034S150	1.50	1.510	2.196	0.062	1.590	2.32
F1034S175	1.75	1.760	2.446	0.062	1.840	2.57
F1034S200	2.00	2.010	2.696	0.062	2.090	2.82
F1034S225	2.25	2.260	2.946	0.062	2.340	3.07
F1034S250	2.50	2.510	3.196	0.062	2.590	3.32
F1034S275	2.75	2.760	3.446	0.062	2.840	3.57
F1034S300	3.00	3.010	3.696	0.062	3.090	3.82
F1034S325	3.25	3.260	3.946	0.062	3.340	4.07
F1034S350	3.50	3.510	4.196	0.062	3.590	4.32
F1034S375	3.75	3.760	4.446	0.062	3.840	4.57
F1034S400	4.00	4.010	4.696	0.062	4.090	4.82
F1034S450	4.50	4.510	5.196	0.062	4.590	5.32
F1034S500	5.00	5.010	5.696	0.062	5.090	5.82
F1034S550	5.50	5.510	6.196	0.062	5.590	6.32
F1034S600	6.00	6.010	6.696	0.062	6.090	6.82

ENGLISH (inches)						
PART NUMBER	TUBE SIZE OUTSIDE DIAMETER	(A) FLANGE INSIDE DIAMETER	(B) FLANGE DIAMETER	(C) MINIMUM THICKNESS	(D) OPENING DIAMETER	COUPLING DIAMETER
F1039S100	1.00	1.010	1.724	0.050	1.260	1.81
F1039S125	1.25	1.260	1.974	0.050	1.510	2.06
F1039S150	1.50	1.510	2.224	0.050	1.760	2.31
F1039S175	1.75	1.760	2.474	0.050	2.010	2.56
F1039S200	2.00	2.010	2.724	0.050	2.260	2.81
F1039S225	2.25	2.260	2.974	0.050	2.510	3.06
F1039S250	2.50	2.510	3.224	0.050	2.760	3.31
F1039S275	2.75	2.760	3.474	0.050	3.010	3.56
F1039S300	3.00	3.010	3.724	0.050	3.260	3.81
F1039S325	3.25	3.260	3.974	0.050	3.510	4.06
F1039S350	3.50	3.510	4.224	0.050	3.760	4.31
F1039S375	3.75	3.760	4.474	0.050	4.010	4.56
F1039S400	4.00	4.010	4.724	0.050	4.260	4.81
F1039S450	4.50	4.510	5.224	0.050	4.760	5.31
F1039S500	5.00	5.010	5.724	0.050	5.260	5.81
F1039S550	5.50	5.510	6.224	0.062	5.760	6.31
F1039S600	6.00	6.010	6.724	0.062	6.260	6.81

STRAPS & STRAP ASSEMBLIES

Made-to-Order

Clampco heavy-duty stainless steel strap assemblies are frequently specified for industrial, commercial, aerospace and defense applications. Straps are commonly used to secure custom shapes to mounting surfaces.

Lengths range from 2.25 in. up to the customer's desired length. For certain applications, strap assemblies may be joined together to arrive at the required length. Customers specify latch styles, material gauge, band width and hardware. Custom anti-vibration liners can also be affixed to the strap surface, if desired. Clampco can preform straps to closely match your application, and reduce assembly time during installation.



DETERMINING BAND STRAP LENGTH

1. METHOD ONE

Using Calipers

Measure the overall length of the strap from the outside of each loop or band end with calipers as shown in the illustration. Keep the strap as flat as possible while measuring the length.

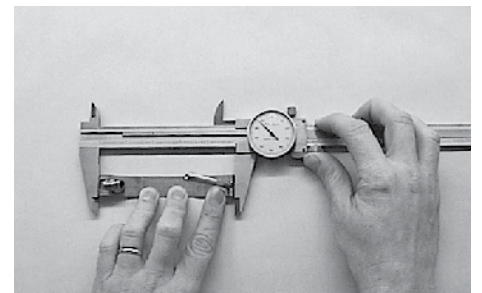

2. METHOD TWO

Using Tape Rule

When the strap length is longer than available calipers, carefully measure the overall length of the strap from the outside of each loop or band end with a tape rule as shown in the illustration. Keep the strap as flat as possible while measuring the length.

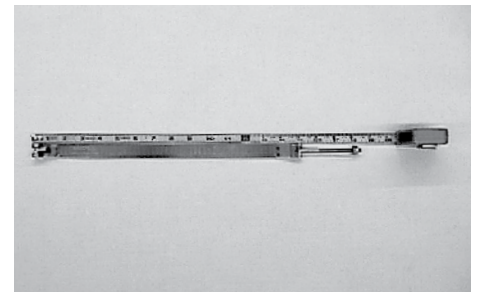

SPECIFICATIONS

CLAMPCO STRAPS

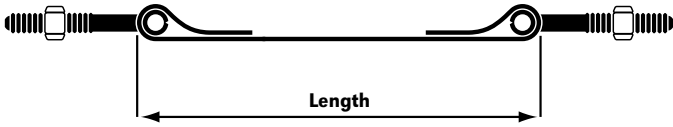

DOUBLE T-BOLT

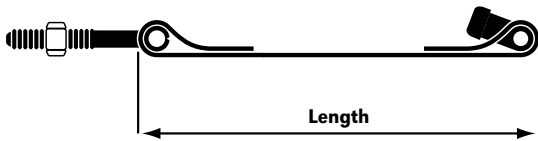

T-BOLT AND TRUNNION

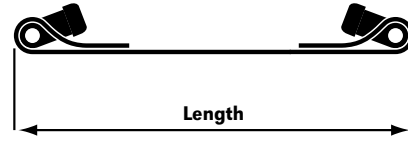

DOUBLE TRUNNION

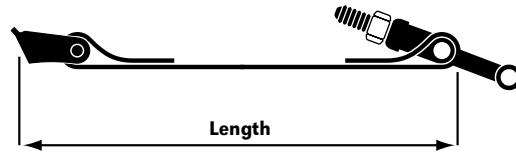

QUICK RELEASE AND T-BOLT

CLAMPCO STRAP ASSEMBLIES

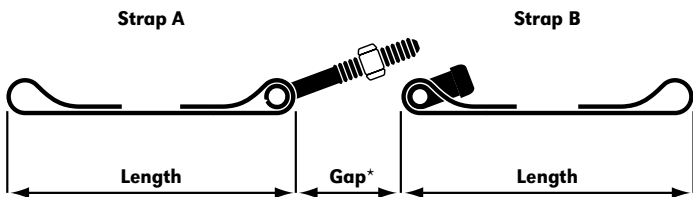

T-BOLT/TRUNNION LATCH WITH EMPTY LOOPS

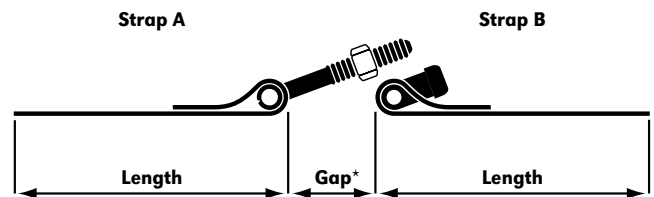

T-BOLT/TRUNNION LATCH WITH FLAT ENDS

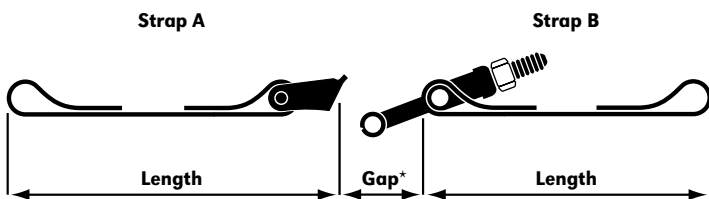

QUICK RELEASE/T-BOLT LATCH WITH EMPTY LOOPS

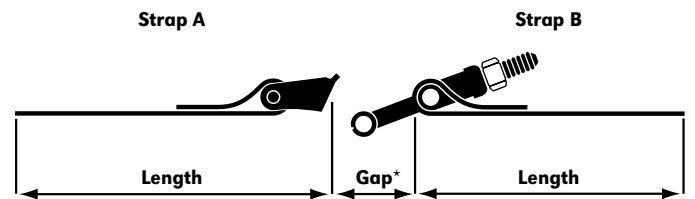

QUICK RELEASE/T-BOLT LATCH WITH FLAT ENDS

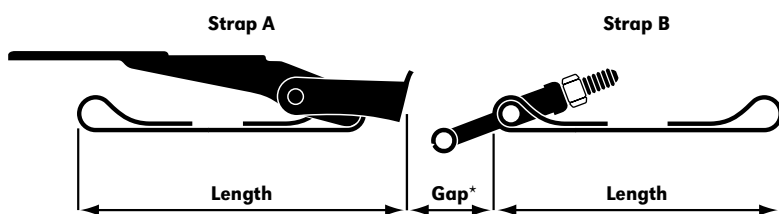

OVER CENTER/T-BOLT LATCH WITH EMPTY LOOPS

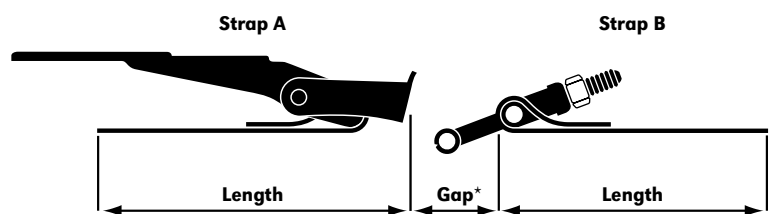

OVER CENTER/T-BOLT LATCH WITH FLAT ENDS

NOTE: *Gap dimensions vary depending upon the type and size of hardware required for each application.

CLAMPCO CUSTOM DESIGN PRODUCTS



We Customize Clamps to Meet Your Specific Needs

Clampco offers a wide variety of custom design features to suit your specific application. The clamps pictured on these pages show just some of the available options.

- A.** Clamp with welded lugs to hold a heat shield around the clamp.
- B.** Clamp with sliding mounting bracket typically used for Performance Racing Fuel Pumps, Overflow Catch Cans and Fire Suppression Tanks.
- C.** Lug Clamp for attaching clamp to other structures. Customers can specify any number of sliding lugs.
- D.** Clamp with rolled edge liner to prevent hose damage.
- E.** Saddle Latch Clamp with visible indicator on bolt to prevent over-tightening.
- F.** Clamp with sliding clips for attaching clamp to other structures. Customers may specify any number of clips.
- G.** Roll formed lighting ring clamp with simple spring closure. Lighting rings are used to hold lenses to light housings.
- H.** Strap assembly with rubber pads to protect the object being held in place.
- I.** Quick Release Clamp with long knob to prevent interference with clamp band. Knob allows operation of clamp without tools.
- J.** Clamp with heat shrink cover to protect the object being clamped.

K. V-Band Coupling with an over center latch handle and a safety clip to prevent accidental opening.

L. Extra wide V-Band Coupling for holding filter housings together. V-Band also has a special long nut to provide easier wrenching.

M. Heavy-duty V-Band Coupling with a long, non-standard, fabricated T-Bolt.

N. Worm Gear V-Band Coupling that offers an economical solution for joining plastic valves and couplings.

O. V-Band Coupling with spherical v-retainers for improved exhaust leak rate due to radial pipe misalignment.

P. V-Band Coupling with long knob allowing for hand tightened installation typically used for small residential water filters.

Q. V-Band Coupling with quick release barrel/socket head cap screw hardware that offers quick assembly without dealing with a deep socket installation.

R. V-Band Coupling with a light-duty over center latch handle. The handle can be secured with a safety pin, which passes through the hole in the yoke.

S. V-Band Coupling with a medium-duty over center latch handle and a safety clip to prevent accidental opening of the clamp.

T. Hinged V-Band Coupling offers excellent installation flexibility.

U. V-Band Coupling with quick release latch provides quick and easy access to joints.



NOTE:

Over-center handles are not to be used for pressurized V-Band applications.

LATCHES, FASTENERS & HANDLES

Custom Options



Latches

Several latch designs are available for light-duty applications. The latches pictured at left show just some of the custom options. For example, latch designs can include metric hardware, socket head cap screws, special square nuts and more. Contact Clampco to discuss your custom latch requirements.

(Note: Not for use on pressurized applications.)

Knobs

Clampco offers various plastic and metal knobs for custom light-duty applications that require an easy tool-less assembly and disassembly for frequent maintenance. Plastic knobs have a brass threaded insert and should not be used for high temperature applications. (See Page 9 for more details.)

The knurled knob is 300 series stainless steel and is a high-quality option for sanitary applications. The knurled knob is a popular choice for clamp applications on food and chemical processing and transportation equipment.

(Note: Not recommended for pressurized applications.)



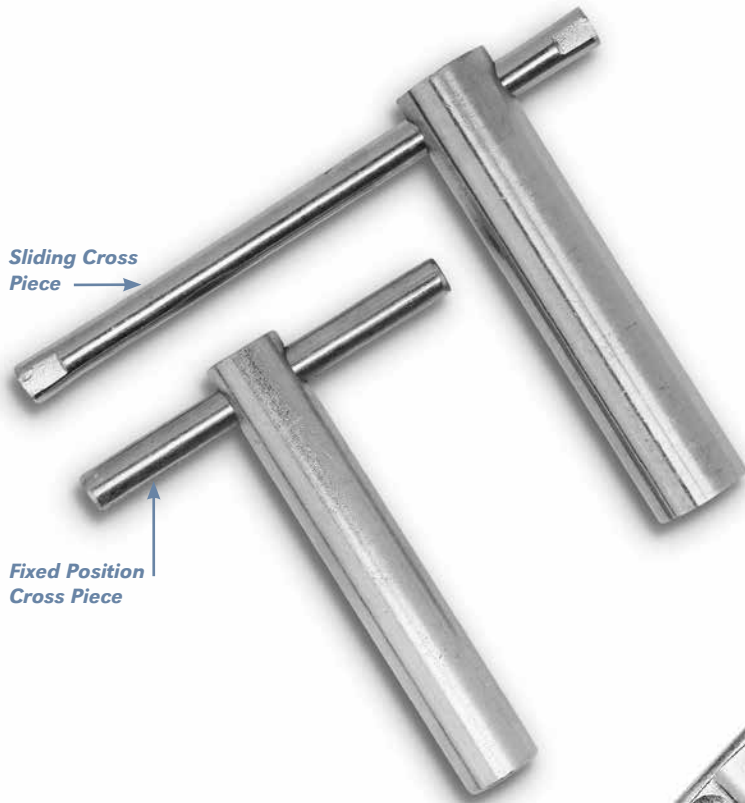

Handles

Clampco offers several over center latch handle designs. The over center latches pictured at right show our captured and slotted yoke designs. A captured yoke holds the T-Bolt in place when operators open the over center latch, while a slotted yoke lets the T-Bolt fall away from the clamp assembly. Your application requirements will determine what yoke style is the best option.

Several safety features are also available with the over center latch handles. These options prevent accidental opening of the clamp. The light-duty over center latch handle can include a safety clip, which flips over the end of the handle. Another option is a safety pin, which locks the yoke to the handle.

The medium-duty over center handle is available with a safety pin or a safety clip. Once again, the safety pin locks the yoke to the handle and must be removed prior to opening the clamp. The safety clip works by providing interference with the handle and must be pressed down in order to fully open the handle.

(Note: Not for use on pressurized applications.)

T-Handles

For tool-less installation applications requiring a more robust option, Clampco offers T-Handles manufactured from zinc plated carbon steel and various grades of stainless steel.

T-Handles are commonly used in Fluid Filtration, Pulp Paper Manufacturing, Pharmaceutical Blending and Telecommunications Equipment. See page 9 for more details.

(Note: Not recommended for pressurized applications.)

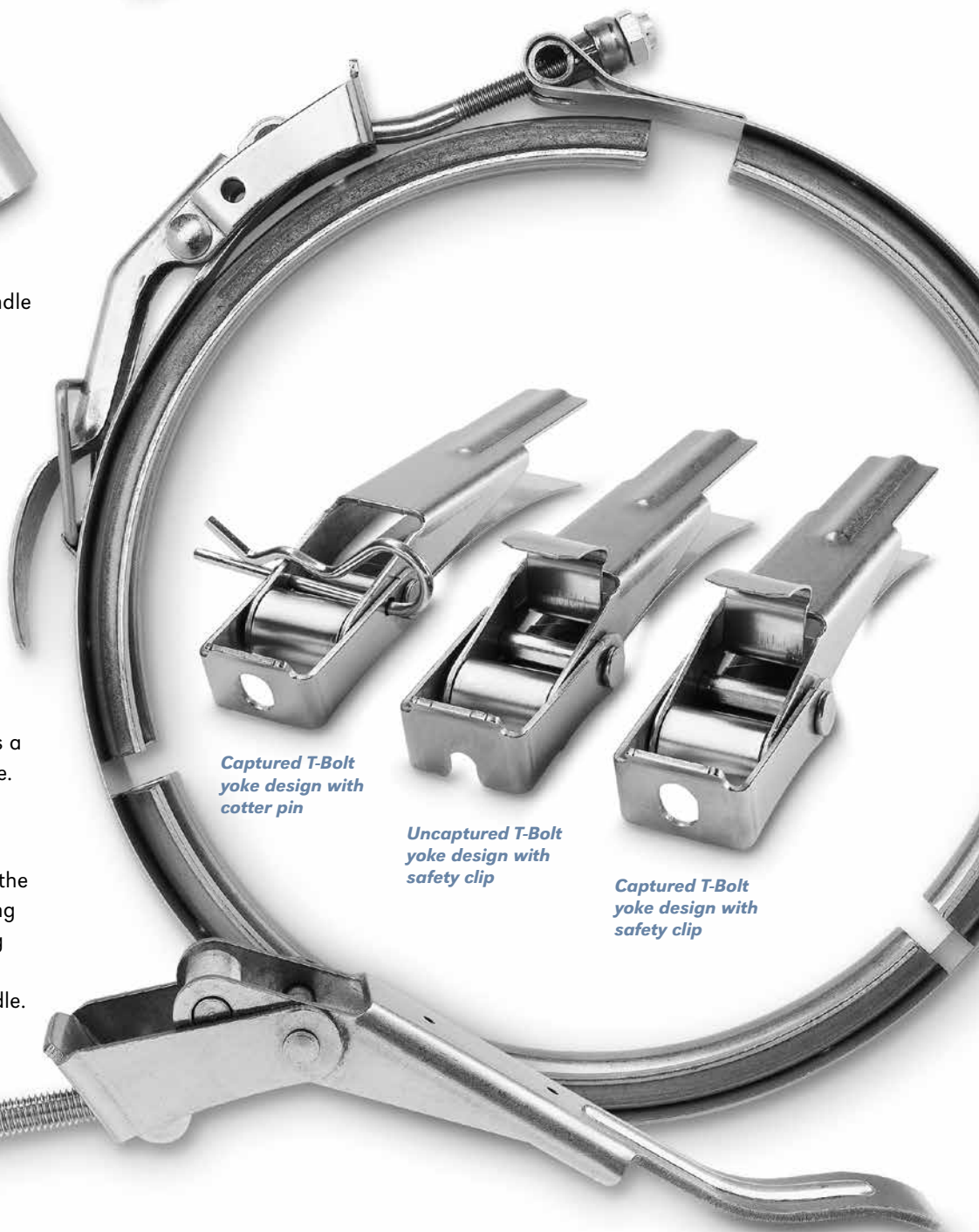

CUSTOM AEROSPACE & DEFENSE CLAMPS

In addition to supplying MS21920 Clamps, Clampco is an approved source for hundreds of other current and legacy Defense/Aerospace part numbers, many of which are registered NSN's (National Stock Number).

Clampco maintains an AS9100 quality management system and will execute contracts in accordance with the rigorous quality requirements common in the Aerospace and Defense market segments.



When standard materials, such as 300 series stainless steel, will not meet the demanding performance requirements of certain applications, Clampco has the ability to use high-performance, aerospace grade materials and processes. For applications that require reduced weight, additional strength at elevated temperatures, or those which operate in severe environments, Clampco has the experience and solutions to meet those needs. Some examples of special materials and processes include, but are not limited to the following:

Materials - 316, 321, A286, Inconel, Hastelloy, Aluminum, Titanium, 17-7PH

Processes - AWS D17.2 Welding, Passivation, Heat Treatment, Stress Relief, Electropolish, Plating

Custom applications often require special clips, brackets or lugs for mounting duct, bottles and hoses. Sliding lugs, clips and brackets provide engineers and technicians installation flexibility, while welded lugs and brackets can be used for heavy-duty applications.

Clampco can also manufacture custom T-Bolt Clamps, Strap Assemblies, and V-Band Couplings to customer drawings or specifications, and can supply special painting, part marking and packaging requirements. Contact us to speak with our knowledgeable Sales Engineers and learn more about our manufacturing capabilities.



TESTING CAPABILITIES

3-D Printing

- Form, Fit and Function – Prototypes
- Evaluation Failures
- Inspection Fixtures

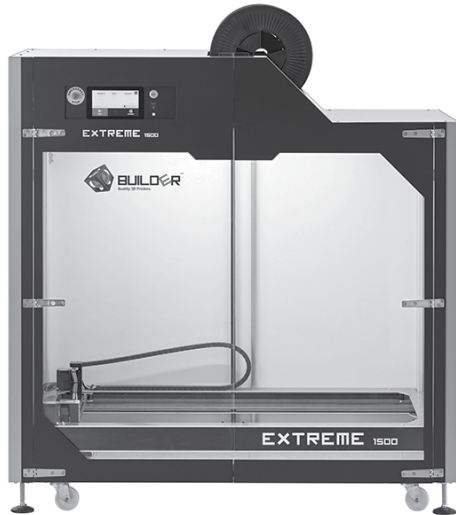

Junker's Testing

- Torque to Tension Relationship
- Accurately Predict Clamping Loads Across Varying Fastener Combinations



Tension/Load Testing

- Proof Load Testing
- Test to Failure
- Axial Load Testing
- Torque to Tension

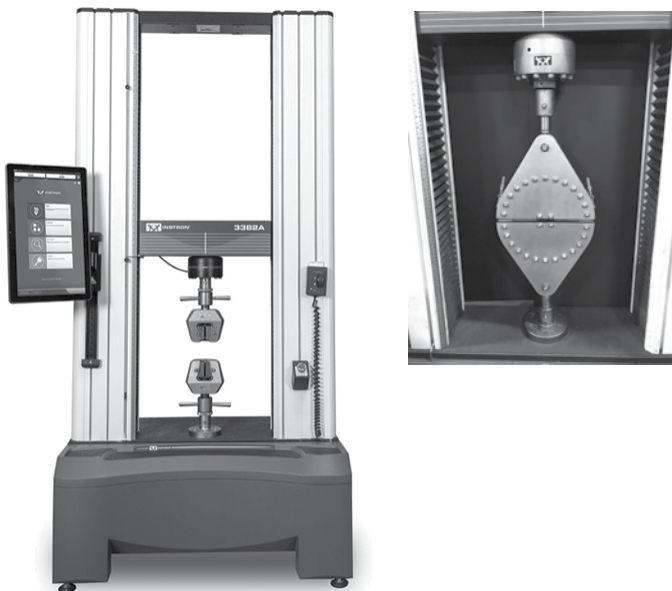

Additional Capabilities

- Weld Testing per AWS D17.2
 - Tensile testing
 - Chemical etching – Weld Cross Section
- Optical Comparator
- Poke-Yoke Error Proofing
- Vision Inspection
- Dye Penetrant Inspection
- Hydrostatic Pressure Testing
 - Validate Axial Load and Internal Pressure Capabilities of V-Band Couplings

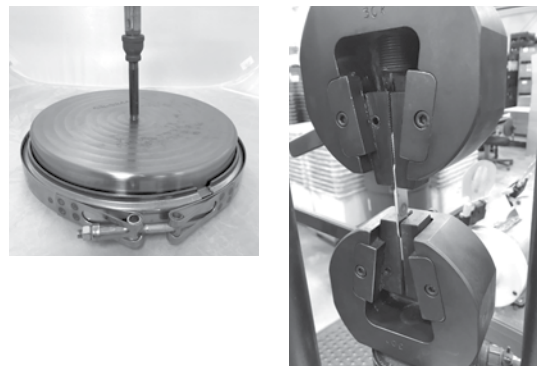

How to determine NOMINAL SIZE FOR YOUR HOSE CLAMP

1. METHOD ONE

Using Calipers

Use calipers to measure the outside diameter (O.D.) of the hose and fitting application with the hose assembled on the pipe or tube fitting as shown in illustration 1a. Use this measurement to specify the nominal clamp size.

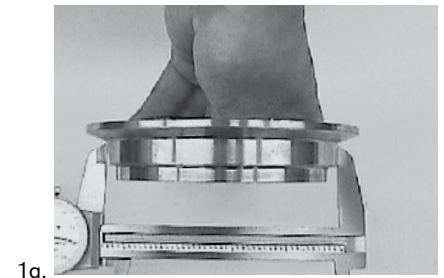

OR

Using Tape Rule

Use a narrow tape rule to measure the circumference of the hose and fitting application with the hose assembled on the pipe or tube fitting as shown in illustration 1b. Denote this as circumference, (C).

Use the formula: **Nominal Application Diameter, $ND = C \div 3.1416$**



OR

Using "Pi" Tape Rule

Use a "pi" tape rule to measure the O.D. of the hose and fitting application with the hose assembled on the pipe or tube fitting as shown in illustration 1c. Use this measurement to specify the nominal clamp size.



2. METHOD TWO

1. Use calipers to measure the O.D. of the pipe or tube fitting as shown in illustration 1d. This diameter may also be measured with a narrow tape rule or "pi" tape rule as shown in illustrations 1b and 1c. Denote this dimension as diameter, (d).
2. Use calipers to measure the material thickness of the hose as shown in illustration 1e. Denote the thickness dimension as thickness, (t).

Use the formula: **Nominal Application Diameter, $ND = d + (2 \times t)$**

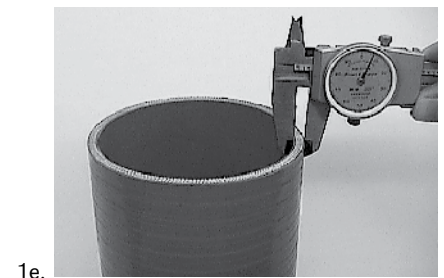
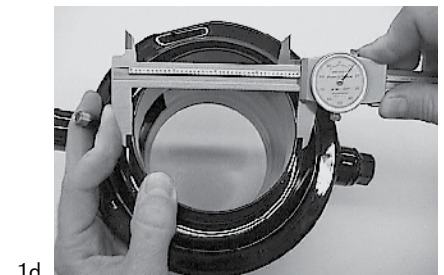

How to determine PROPER DIMENSIONS FOR YOUR V-BAND COUPLING APPLICATION

OUTSIDE FLANGE DIAMETER

Using Calipers

Use calipers to measure the largest or “outside” diameter of your flange as shown in illustration 1b. (or use a “pi” tape rule as shown in illustration 1c.) Denote this outside flange diameter as “fd”.

1a.



1b.

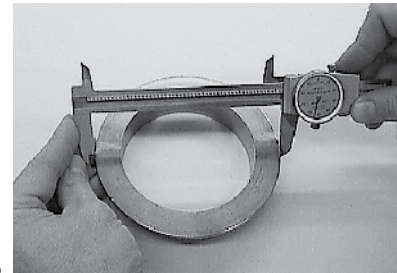

OR

USING TAPE RULE

Use a narrow tape rule to determine the flange circumference (C) as shown in 1c.

Use the formula: **Flange Diameter = $C \div 3.1416$**

1c.

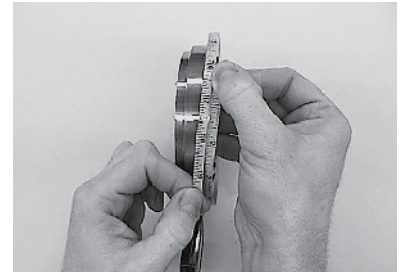

FLANGE BASE DIAMETER

Use calipers to measure the “base” diameter of your flange as shown in illustrations 2a and 2b. This dimension can also be measured with a narrow tape rule or with a “pi” tape rule as shown in illustration 1c. Denote this base diameter as “bd”.

2a.

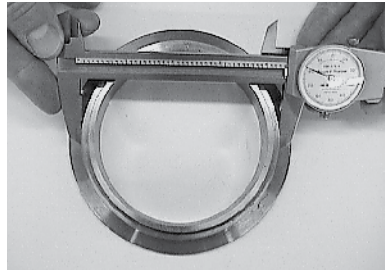

2b.

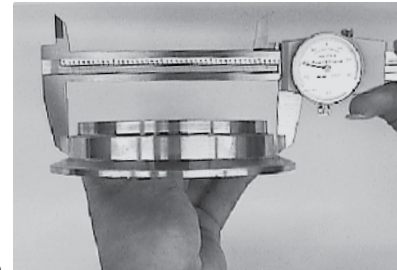

FLANGE HEIGHT CALCULATION

To determine the height of your flange, you can use the previously measured outside flange diameter “fd”, and the flange base diameter “bd”.

Use the formula: **Flange Height, fh = $(fd - bd) \div 2$**

FLANGE APEX

This dimension is best determined by measurement with an optical comparator or from the actual design print of the flange. However, it can be measured with great care using calipers as shown in illustration 4a. Denote this flange apex as “a”.

*Remember that O-rings and gaskets will change your final width dimensions.

4a.

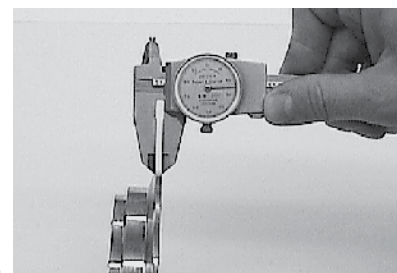

FLANGE BASE WIDTH

This dimension is best determined by measurement with an optical comparator or from the actual design print of the flange. However, it can be measured with great care using calipers as shown in illustration 5a. Denote this flange apex as “w”.

*Remember that O-rings and gaskets will change your final width dimensions.

5a.

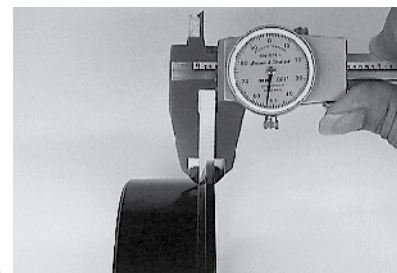

FLANGE ANGLE

This dimension is best determined by measurement with an optical comparator or from the actual design print of the flange. However, it can be determined by using the previously measured flange apex “a”, flange base width “w”, and flange height “fh”.

Use the formula: **Flange Angle = $TAN^{-1} [(w - a) \div fh]$**

V-BAND CLAMP/COUPLING LOAD FORMULAS

V-Band Couplings must be designed to provide an axial preload that exceeds the total in-service loads. These loads include: internal pressure; bending moments; and axial tension. For economy, the V-Band Coupling should be designed based on the minimum strength required for the application loading. See the formulas below to determine your application loads or contact a Clampco sales engineer for assistance.

SYMBOLS

- L_p = Load Intensity due to Pressure, lbs./in. of circumference
- L_b = Load Intensity due to Bending Moment, lbs./in. of circumference
- L_a = Load Intensity due to Axial Tension, lbs./in. of circumference
- L = Total Load Intensity, lbs./in. of circumference
- D = Flange O.D., in.
- P = Internal Pressure, psi
- M = Bending Moment, in.-lbs.
- A = Axial Tension, lbs.

Step 1

Determine the Load Intensity due to Internal Pressure, L_p .

$$L_p = \frac{P \times D}{4}$$

Step 2

Determine the Load Intensity due to Bending Moment, L_b .

$$L_b = \frac{4 \times M}{\pi \times D^2}$$

Step 3

Determine the Load Intensity due to Axial Tension, L_a .

$$L_a = \frac{A}{\pi \times D}$$

Step 4

Determine the Total Load Intensity by adding the results of Steps 1, 2, and 3.

$$L = L_p + L_b + L_a$$

Example

A V-Band Coupling meeting the following:
 Flange O.D., $D = 5.00$ in.
 Internal Pressure, $P = 200$ psi
 Bending Moment, $M = 1000$ in.-lbs.
 Axial Tension Load, $A = 1200$ lbs.

$$L_p = \frac{200 (5.00)}{4} = 250 \text{ lbs./in.}$$

$$L_b = \frac{4 (1000)}{3.14 (5.00)^2} = 51 \text{ lbs./in.}$$

$$L_a = \frac{1200}{3.14 (5.00)} = 76 \text{ lbs./in.}$$

$$L = 250 + 51 + 76 = 377 \text{ lbs./in.}$$

Step 5

Use the formula below to convert the total load intensity to an equivalent operating pressure:

$$P = \frac{4 \times L}{D} = \frac{4 (377)}{5.00} = 302 \text{ psi}^*$$

*Please note:
 Equivalent operating pressure does not include a Factor of Safety.

MATERIALS AND TEMPERATURES

For different materials and temperatures, the pressure chart data must be corrected using the following table:

FAHRENHEIT						CELSIUS				
RETAINER MATERIAL	70°F	200°F	400°F	600°F	800°F	21°C	93°C	204°C	315°C	427°C
301/302/304 SS	1.00	0.88	0.75	0.68	0.60	1.00	0.88	0.75	0.68	0.60
Carbon Steel	0.50	0.46	0.43	0.37	-	0.50	0.46	0.43	0.37	-

BAND STRENGTH

Minimum Yield Strength for 300 Series Stainless Steel 1/2 Hard Temper in in.-lbs. [kilograms]

MATERIAL THICKNESS IN INCHES [MILLIMETERS]	BAND WIDTH IN INCHES [MILLIMETERS]							
	0.500	0.625	0.750	0.875	1.000	1.125	1.250	
0.020 [.51]	1100 [499]	1375 [624]	1650 [748]	1925 [873]	2200 [998]	2475 [1123]	2750 [1247]	
0.025 [.64]	1375 [624]	1716 [780]	2063 [936]	2406 [1091]	2750 [1247]	3094 [1403]	3438 [1559]	
0.031 [.79]	1705 [773]	2131 [967]	2558 [1160]	2984 [1353]	3410 [1547]	3836 [1740]	4263 [1934]	
0.040 [1.02]	2200 [998]	2750 [1247]	3300 [1497]	3850 [1746]	4400 [1996]	4950 [2245]	5500 [2495]	
0.050 [1.27]	2750 [1247]	3438 [1559]	4125 [1871]	4813 [2183]	5500 [2495]	6188 [2807]	6875 [3118]	
0.062 [1.57]	3410 [1546]	4263 [1934]	5115 [2320]	5968 [2707]	6820 [3094]	7673 [3480]	8525 [3867]	

MATERIAL SPECIFICATIONS

Common materials used to manufacture Clampco clamps.

CORROSION RESISTANT MATERIAL	COMMERCIAL DESIGNATION	PROCUREMENT SPECIFICATION
STEEL SHEET & STRIP	TYPE 301 ANNEALED TYPE 301 1/4 HARD TYPE 301 1/2 HARD	AMS 5901 AMS 5517 AMS 5518
STEEL SHEET & STRIP	TYPE 302 ANNEALED TYPE 302 1/4 HARD TYPE 302 1/2 HARD	AMS 5516 AMS 5903 AMS 5904
STEEL SHEET & STRIP	TYPE 304L ANNEALED TYPE 304 ANNEALED TYPE 304 1/4 HARD TYPE 304 1/2 HARD	AMS 5511 AMS 5513 AMS 5910 AMS 5911
STEEL SHEET & STRIP	TYPE 316 ANNEALED TYPE 316 1/4 HARD TYPE 316L ANNEALED TYPE 316 1/2 HARD	AMS 5524 AMS 5907 AMS 5507 ASTM-A-666
STEEL SHEET & STRIP	TYPE 321 ANNEALED	AMS 5510
STEEL BARS & FORGINGS	TYPE 410	AMS 5504
STEEL BARS & FORGINGS	TYPE 431	AMS 5628
STEEL BARS & FORGINGS	TYPE A286	AMS 5723 AMS 5735 AMS 5737
STEEL SHEET & STRIP	TYPE A286 ANNEALED	AMS 5525
STEEL SHEET & STRIP	C276 HASTELLOY	ASTM-B-575
STEEL SHEET & STRIP	6061-T6 ALUMINUM	AMS 4027
STEEL SHEET & STRIP	INCONEL 718	AMS 5596

PERFORMANCE COMPARISON BAND TENSION VS. APPLIED TORQUE

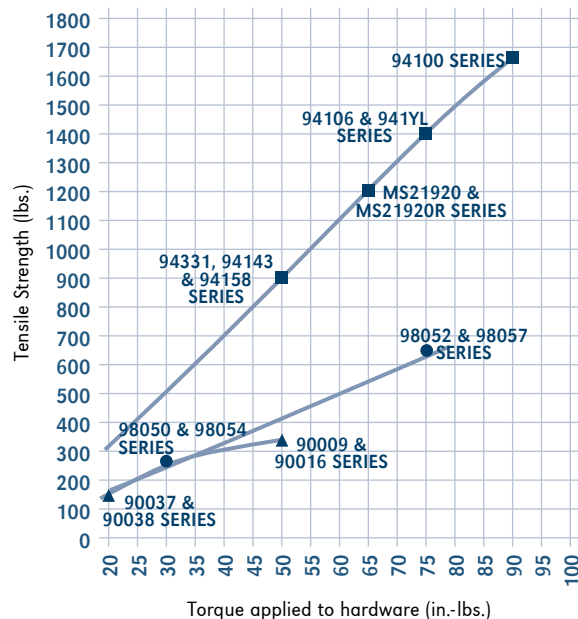

■ T-BOLT BAND CLAMPS

- High performance
- Safe and effective
- Good for light, medium, and heavy-duty applications

● BARREL HARDWARE CLAMPS

- Low profile design
- Good for light and medium-duty applications

▲ WORM DRIVE CLAMPS

- Economical
- Easy-to-use
- Good for light-duty applications



Clampco Products, Inc.
1743 Wall Road
Wadsworth, Ohio 44281
phone **330.336.8857**
fax **330.336.4281**
web **Clampco.com**